

JUNG

# LED Lighting technology

Orientation with system



Staff  
room



In buildings that are open to the public, clear identification is necessary to enable visitors to find their way around. Signs that provide directions and information are however also a useful aid in office buildings,

structure which makes it easy to install. The central element is the power supply which can be connected to 230 V or 24 V. The light signals with their respective frames are simply clipped onto this performance unit.

## ORIENTATION SIGNAGE IN A CLASSIC DESIGN

in large hotel complexes or clinics that cover a wide area. This is particularly the case when the information can also be read in the dark. The LED lighting technology from JUNG creates the prerequisite for a progressive orientation option which meets all requirements. Among the essential benefits of the system is its modular

Due to the integration in the LS switch design, the unified appearance of the interior architectural concept is retained and the user will be convinced by yet another factor. The signals can be replaced at any time without any problems. Due to this high level of flexibility, the identification of the building can be adapted to suit changes of use.

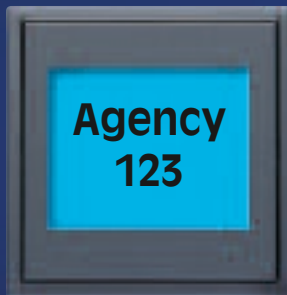

Wherever the new LED light signals are used, attention is immediately drawn to them. This is due firstly to the striking backlighting which is available in the two variants blue and white – depending on the connection to the central unit: the white LEDs are powered for the L and N mains connection; for L and N, however the blue lighting is activated.

The light signals are suitable for continuous operation without any restrictions. The cold light used guarantees that the elements hardly produce any heat. This is the reason why the LED system has such a long service life – yet with the minimum power consumption. A transparent DIN A4 foil can be used for individual labelling of the signals. A conventional laser printer

## VERSATILITY IN APPLICATION AND APPEARANCE

A new version is equipped with a 3-pole DIP-switch which enables the selection of 7 different colours (red, blue, green, yellow, bright-blue, purple and white).

is sufficient attaching text or symbols onto the foil. After cutting it to size, it is inserted into the device from above and can be replaced just as easily when required.

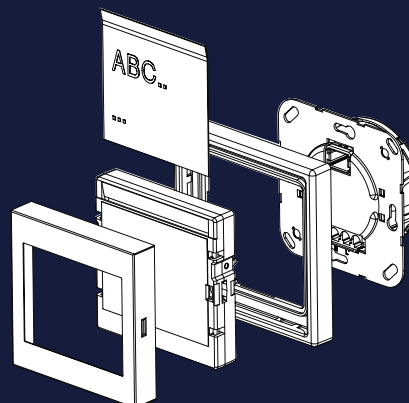

JUNG

Conference  
hall 4



**Do not  
disturb**  
Please  
come in

## CLEAR SIGNALS IN RED AND GREEN

With the help of a special 'traffic light' function, the LED light signal becomes an efficient control and information element, which is required for example in waiting rooms of doctor's practices, hospital rooms or for room service in hotels. The traffic light version is conceived as a two-part display which is backlit with red at the top and green at the bottom. Each of the two fields can be controlled

separately as required via a 2-gang switch so that people who are standing outside the door know exactly whether they may enter or whether they need to wait.

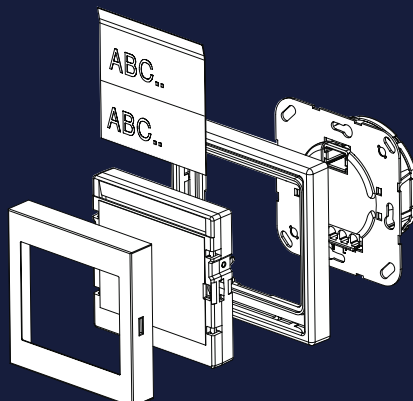
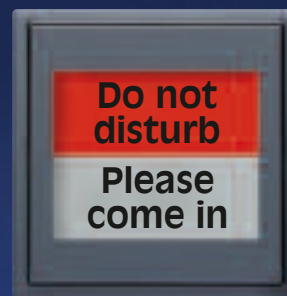

Elevator >>





The information sign is a particularly interesting product from the LED range. Due to its self-illuminating label, it is primarily suitable for orientation in buildings. In these examples shown here, the info sign consist of a centre plate with a 71 x 71 mm or a 71 x 142 mm sheet of plexiglass inserted.

## TRANSPARENT LIGHT SIGNALS FOR ORIENTATION

JUNG offers a professional labelling service for this type of light signal which can be ordered by post or called up via the Internet. The appropriate software is available with a form for entering the required text or symbols. The signs are then labelled according to the template and supplied to the customer as a complete unit.

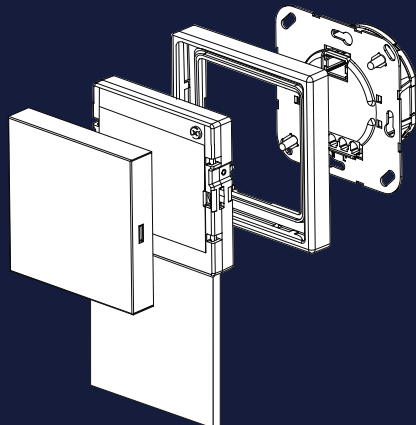

Head physician  
Dr. Carter



The LED lighting system from JUNG stands out due to the extraordinary broad spectrum of labelling options. All conceivable areas of application in the various buildings can thus be im-

An even more convenient option is offered by the labelling of signs which can be produced by the JUNG labelling service according to customer requirements.

# ONE MODULE WITH UNLIMITED POSSIBILITIES

plemented in an innovative way. Symbols for labelling the standard signals are available on the Internet for downloading; text can be printed out onto foils via the PC.

All the symbols for downloading and the convenient labelling software can be found under:

[www.jung-label.de](http://www.jung-label.de)

## Examples of symbols



Due to the modular principle, the installation is carried out very quickly. Simply connect the performance unit to 230 V or 24 V and clip onto the selected frame with the LED signal. It is also possible to replace the light signals at a later date without any problems. A small label can be exchanged for a larger one in the blink of an eye.

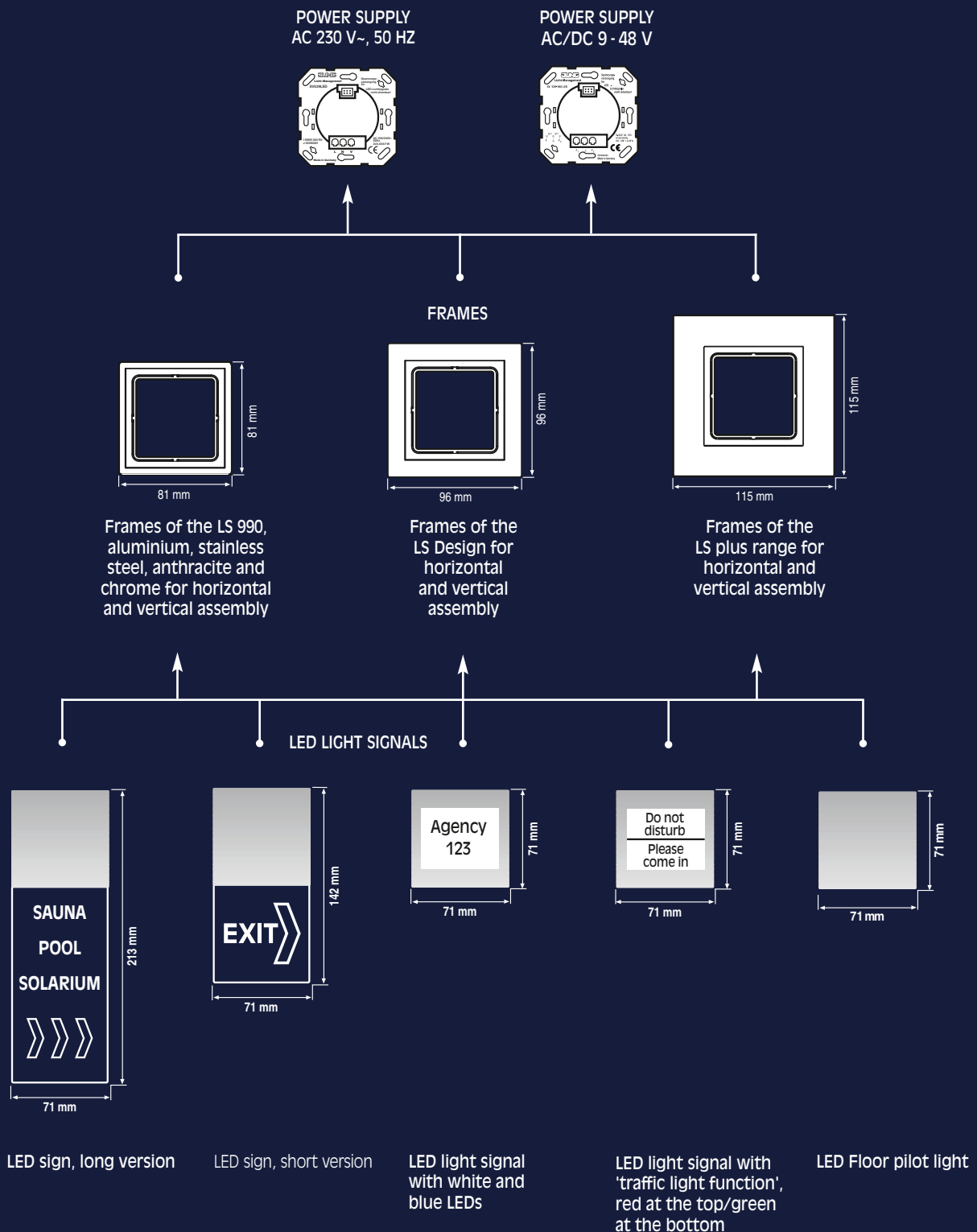



# JUNG

## RELIABLE ORIENTATION IN THE DARK

A wrong step in the dark can have fatal consequences. The problem can be solved elegantly with the LED light signal. Designed as an orientation light, it indicates any sources of danger in good time. Steps or dark corridors are identified without glare by a special light outlet at the bottom. This enables reliable orientation without risks.

The orientation light is available in the designs LS 990, stainless steel, aluminium, anthracite, chrome, LS Design and LS plus.

In the standard range AS 500, JUNG offers an illuminated solution for switches, push-buttons and sockets in the ivory and white.





SCHUKO socket with integrated child protection and illuminated inscription field for AS 500



Switch or push-button with illuminated inscription field for AS 500



SCHUKO socket with integrated child protection and illuminated inscription field for the LS design range

The new back-lighted inscription fields provide optimum identification. The white LED background light ensures, that the inscription field is always clearly legible. This feature is available in the for wall sockets with integrated child protection (AS 500 and LS 990) as well as for rocker switches and push-buttons (AS 500).

Clear  
and  
save

## identification

The inscription fields are permanently connected to the supporting frame even when the covers and outer frames are removed. This effectively prevents mix-ups following renovation in the future.

Protection against moisture is important for applica-

tions in areas requiring maximum hygiene, i.e. in hospitals and senior residences because such locations are frequently cleaned and disinfected. The moisture-proof inscription fields prevent the cleaning agent from penetrating into the inscription field and thereby damaging the label.

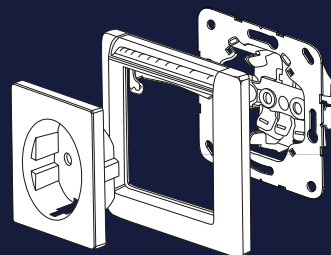

# STUNG





The Design ranges available for the JUNG LED Lighting technology



LS 990 in white



Aluminium



Anthracite



LS 990 in light grey



Stainless steel



Chrome

ALBRECHT JUNG GMBH & CO. KG  
P.O. Box 1320  
58569 Schalksmühle  
Germany

Phone: +49.23 55.80 65 53  
Fax: +49.23 55.80 62 54  
E-Mail: [mail.vka@jung.de](mailto:mail.vka@jung.de)  
Internet: [www.jung.de](http://www.jung.de)

For sales contacts in your country see:  
[www.jung-salescontact.com](http://www.jung-salescontact.com)