



***Fontini***



www.tesli.com

www.tesli.com

www.tesli.com

**Fontini**

**FROM BARCELONA TO THE WORLD**  
**INSPIRATION, INNOVATION, CREATIVITY,**  
**THIS IS THE SPIRIT THAT WE TRY TO CAPTURE IN OUR CREATIONS**

HEADQUARTERS  
Pol. Ind. Can Bernades-Subirà C/ Anoia, 15  
08130 SANTA PERPÈTUA DE MOGODA  
(Barcelona) SPAIN

SHOWROOM  
Ronda Segovia, 61  
Portal 2, Local 3  
28005 MADRID (SPAIN)

TEL.: (+34) 93.574.33.30  
FAX: (+34) 93.574.21.19  
LET'S TALK:  
(+34) 902.120.103



**Fontini**



**Detrás de una gran empresa, siempre hay un gran equipo de profesionales que con su empeño diario hacen realidad cada proyecto. En Fontini, sentimos pasión por lo que hacemos, por el trabajo bien hecho, por los compromisos cumplidos.**

**Queremos agradecer a todos, clientes y distribuidores, la confianza que habéis depositado en nosotros durante más de 50 años y que nos ha permitido crear una de las marcas de mecanismos eléctricos decorativos más prestigiosas y reconocidas a nivel mundial.**

Behind a successful company, there is always a great team. Professionals who with their daily determination make any project come true. In Fontini we have passion with our work, with the accomplished commitments.

We would like to thank you, clients and distributors for trusting us for more than 50 years. You make possible that we create one of the biggest brand of decorative mechanisms in the market.

*Derrière une grande entreprise, se cache toujours une grande équipe. Des professionnels qui, avec leur travail quotidien et motivation, font de chaque projet une réalité. Chez Fontini, nous ressentons de la passion pour ce que nous faisons, pour le travail bien fait, pour les promesses tenues.*

*Nous tenons à vous remercier, clients et distributeurs, pour la confiance que vous nous avez accordée durant plus de 50 ans et qui nous a permis de créer une des marques de mécanismes électriques décoratifs les plus prestigieuses et reconnues au monde.*

**Roger Font · CEO Fontini Group**



# CERTIFICACIONES CERTIFICATIONS CERTIFICATS



## EXIJA CALIDAD, EXIJA FONTINI

La calidad, fiabilidad y seguridad de nuestros productos son fundamentales.  
 Disponemos de certificados de calidad ISO 9001:2000 y certificados de producto AENOR, NF y GOST, cumpliendo las normativas europeas de reglamentación electrotécnica de baja tensión.

## REQUIRE QUALITY. REQUIRE FONTINI

Quality, reliability and safety of our products are essential.  
 We hold ISO 9001:2000 quality certificates and AENOR, NF and GOST product certificates, fulfilling the European laws of Low Voltage Electrotechnical Regulation.

## EXIGEZ LA QUALITÉ, EXIGEZ FONTINI

La qualité, la fiabilité et la sécurité de nos produits sont fondamentales.  
 Nous disposons des certificats de qualité ISO 9001 : 2000 et certificats de produits AENOR, NF et GOST, qui répondent aux normes européennes de réglementation électrotechnique de basse tension.



## PERSONALICE SU PRODOTTO:

En Fontini nos adaptamos a sus necesidades y le ofrecemos la posibilidad de personalizar nuestras colecciones, desde una marca especial para un hotel, hasta un color, una textura, un material o un proyecto de diseño completo para ediciones limitadas.

Ponemos a su disposición un equipo humano y técnico para ayudarle a conseguir el mejor resultado en la adaptación o el desarrollo de producto

Foto: Pulsador - Hotel Villamagna, Madrid (edición especial limitada)  
Diseño: Thomas Urquijo - Resco Decoración

## CUSTOMIZE YOUR PRODUCT:

In Fontini we adapt ourselves to your needs offering the possibility to customize your collections:  
From a special hotel logo-brand name, up to a color, a texture, a material or a limited edition design project.

Therefore, we have an exclusive service of personal attention at your disposal to advise you on the adjustment or the development of the product.

Photo: Pushbutton - Villamagna Hotel, Madrid (special limited edition)  
Design: Thomas Urquijo - Resco Decoración

## PERSONNALISEZ VOTRE PRODUIT :

Chez Fontini, nous nous adaptons à vos besoins et vous offrons la possibilité de personnaliser nos collections, d'une marque spéciale pour un hôtel à une couleur, une texture, un matériel ou un projet de design complet pour des éditions limitées.

Nous mettons à votre disposition humaine et technique afin de vous conseiller et obtenir les meilleurs résultats possibles sur l'adaptation ou le développement d'un produit.

Photo: Bouton poussoir - Hôtel Villamagna, Madrid (édition limitée spéciale)  
Design: Thomas Urquijo - Resco Decoración



**P.04**  
**NOVEDADES**  
**NOVELTIES**  
**NOUVEAUTES**



**P.06**  
**COLECCIONES DE EMPOTRAR**  
**FITTING INSTALLATION COLLECTIONS**  
**COLLECTIONS POUR INSTALLATION ENCASTRÉE**

P.06 F-37 ROTARY & ROCKING SWITCHES COLLECTION  
P.24 VENEZIA ROTARY & ROCKING SWITCHES COLLECTION  
P.46 GARBY COLONIAL COLLECTION



**P.58**  
**COLECCIONES DE SUPERFICIE/EMPOTRAR**  
**SURFACE & FITTING INSTALLATION COLLECTIONS**  
**COLLECTIONS POUR INSTALLATION EN SAILLIE/ ENCASTRÉE**

P.58 GARBY COLLECTION  
P.68 DIMBLER COLLECTION



**P.74**  
SISTEMAS DECORATIVOS DE INSTALACIÓN EN SUPERFICIE  
DECORATIVE SURFACE INSTALLATION SYSTEMS  
SYSTÈMES DÉCORATIFS D'INSTALLATION EN SAILLIE



**P.88**  
COMPLEMENTOS & SONIDO  
COMPLEMENTS & SOUND  
COMPLEMENTS & SON

P.88 COMPLEMENTS  
P.94 SOUND



**P.96**  
INFORMACIÓN TÉCNICA  
TECHNICAL INFORMATION  
INFORMATION TECHNIQUE



# NOVEDADES NOVELTIES NOUVEAUTES





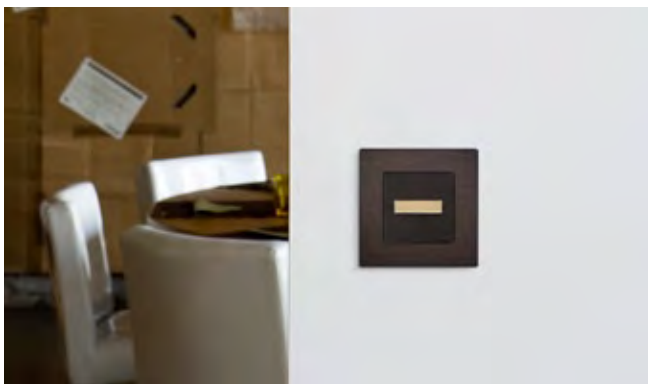

## NUEVOS ACABADOS NEW FINISHES NOUVELLES FINITIONS

**Mecanismos F-37 Rocking y Rotary switches en dorado y patiné americano** Golden and antique bronze F-37 Rocking & Rotary switches *Mécanismes F-37 Rocking et Rotary switches en doré et bronze ancien*

**Mecanismos F-37 Rocking switches con manecilla cuadrada** F37 Rocking switches with square key *Mécanismes F-37 Rocking switches avec manette carrée*

**Marcos Venezia Metal patiné cobre, cobre antiguo y antracita** Patinated cooper, antique cooper & anthracite Metal Venezia frames *Plaques Venezia Métal patiné cuivre, cuivre ancien et anthracite*

**Marcos Venezia Metal para mecanismos F-37** Metal Venezia frames for F-37 mechanisms *Venezia Métal pour mécanismes F-37*

**Marcos Garby Colonial en madera decapada** Pickling wood Garby Colonial frames *Plaques Garby Colonial en bois décapé*

**Colecciones Garby y Garby Colonial en porcelana negra** Black porcelain Garby & Garby Colonial Collections *Collections Garby & Garby Colonial en porcelaine noire*

**Dimbler cuerpo de porcelana blanca** White porcelain case Dimbler *Dimbler corps en porcelaine blanche*



## NUEVOS SISTEMAS DECORATIVOS DE INSTALACIÓN EN SUPERFICIE

NEW DECORATIVE SURFACE INSTALLATION SYSTEMS

NOUVEAUX SYSTÈMES DÉCORATIFS D'INSTALLATION EN SAILLIE

**Cajas metálicas en acabado níquel satinado para instalación en superficie de las Colecciones F-37 Rocking y Rotary switches** Metallic boxes for F-37 Rocking & Rotary switches Collections surface installation *Boîtes métalliques pour installation en saillie des Collections F-37 Rocking & Rotary switches*

**Cajas de empalmes metálicas de 3 tamaños distintos en acabados níquel satinado y metal envejecido** 3 different size metallic connection boxes satin nickel-plated and aged metal finishes *Boîtes de dérivation métalliques de 3 tailles différentes avec finitions nickel satiné et métal vieilli*

**Cajas metálicas de 2 elementos para instalación de mecanismos y accesorios de las colecciones Venezia y Garby Colonial** 2 element metallic boxes for Venezia & Garby Colonial Collections mechanisms & accessories installation *Boîtes métalliques de 2 éléments pour installation de mécanismes et accessoires des collections Venezia et Garby Colonial*



## NUEVAS FUNCIONES NEW FUNCTIONS NOUVELLES FONCTIONS

**Doble telefonía y doble RJ categoría 6 para todas las colecciones Fontini** Double telephone & 6 RJ category for all Fontini collections *Double prise téléphone et double RJ catégorie 6 pour toutes les collections Fontini*

**Pulsador tipo Rocking** Rocking Pushbutton *Bouton poussoir Rocking*

**Doble pulsador tipo Rocking** Rocking double pushbutton *Double bouton poussoir Rocking*

**Pulsador temporizador** Timer pushbutton *Bouton poussoir temporisateur*

**Baliza luminosa/Baliza de emergencia** Luminous marker / Emergency marker *Balise lumineuse/Balise d'urgence*



www.tesli.com

www.tesli.com

www.tesli.com

Interiorismo: Carmen Barasona  
Interior Design: Carmen Barasona  
Architecture d'intérieur: Carmen Barasona

## F-37 Rocking and Rotary switches Collection

www.tesli.com

www.tesli.com

Interiorismo: Carmen Barasona – Fotografía: Benjamín Alcázar  
Interior Design: Carmen Barasona – Photography: Benjamín Alcázar  
Architecture d'intérieur: Carmen Barasona – Photographie: Benjamín Alcázar

**Instalación empotrada.**

**Mecanismos de 10AX - 250V~**

**Bases de enchufe de 16A -250V~**

**Contactos de plata de alto poder de ruptura.**

**Marcos de madera maciza de fresno y cristal fundido.**

**Marcos para instalar en posición vertical u horizontal.**

**Instalación en caja universal con tornillos.**

Fitting installation.

10AX - 250V~ mechanisms.

10/16A - 250V~ earthing sockets.

Silver contacts with high breaking power.

Massif ashtrée wood and melt glass frames.

Frames for vertical or horizontal installations, fitted in universal boxes.

Installation in standard box with screws.

*Installation encastrée.*

*Mécanismes de 10A - 250V~*

*Prises de courant 10/16A - 250V~*

*Contacts d'argent avec haut pouvoir de rupture.*

*Plaques en bois massif frêne et verre.*

*Plaques pour installation verticale ou horizontale.*

*Installation sur boîte standard avec vis.*



# F-37 ROCKING SWITCHES

NEW



**Manecilla cromada cuadrada, carátula blanca, marco cristal blanco**

Square chrome-plated key, white cover, white glass frame

*Manette carrée chromée, intérieur blanc, plaque verre blanc*

NEW



**Manecilla cromada cuadrada, carátula metalizada, marco madera wengé**

Square chrome-plated key, metallic cover, wengue wood frame

*Manette carrée chromée, intérieur blanc, plaque bois wengué*



**Manecilla cromada, carátula blanca, marco cristal azul reflex**

Chrome-plated key, white cover, blue reflex glass frame

*Manette chromée, intérieur blanc, plaque verre bleu reflex*



**Manecilla cromada, carátula blanca, marco mader cerezo**  
Chrome-plated key, white cover, cherry tree wood frame  
*Manette chromée, intérieur blanc, plaque bois merisier*



**Manecilla dorada, carátula marrón, marco mader wengé**  
Golden key, brown cover, wengue wood frame  
*Manette dorée, intérieur marron, plaque bois wengué*



**Manecilla patiné americano, carátula marrón, marco mader tabaco**  
Antique bronze key, brown cover, tobacco wood frame  
*Manette bronze ancien, intérieur marron, plaque bois tabac*

# F-37 ROTARY SWITCHES



**Lazo acero inox, carátula blanca, marco cristal blanco**

Stainless steel knob, white cover, white glass frame  
*Bouton acier inoxydable, intérieur blanc, plaque verre blanc*



**Lazo acero inox, carátula blanca, marco cristal azul reflex**

Stainless steel knob, white cover, reflex blue glass frame  
*Bouton acier inoxydable, intérieur blanc, plaque verre bleu reflex*



**Lazo acero inox, carátula metalizada, marco madera wengé**

Stainless steel knob, metallic cover, wengue wood frame  
*Bouton acier inoxydable, intérieur métallisé, plaque bois wengué*





**Lazo acero inox, carátula metalizada, marco madera cerezo**

Stainless steel knob, metallic cover, cherry tree wood frame

*Bouton acier inoxydable, intérieur métallisé, plaque bois merisier*



**Lazo dorado, carátula marrón, marco madera wengé**

Golden knob, brown cover, wengue wood frame

*Bouton dorado, intérieur marron, plaque bois wengué*



**Lazo patiné americano, carátula marrón, marco madera tabaco**









Antique bronze knob, brown cover, tobacco wood frame

*Bouton bronze ancien, intérieur marron, plaque bois tabac*

# F-37 Rocking Switches Collection

	Serie Set Série	Código Code Cod	Acabado Finish Finition	Embalaje Packaging Emballage	
 <p><b>Interruptor unipolar 10AX - 250V~</b> One pole switch 10AX - 250V~ Interrupteur unipolaire 10AX-250V~ <b>Conmutador 10AX - 250V~</b> Two-way switch 10AX - 250V~ Va-et-vient 10AX-250V~ <b>Cruzamiento 10AX - 250V~</b> Crossing switch 10AX - 250V~ Permutateur 10AX-250V~ <b>Interruptor bipolar 10AX - 250V~</b> Two pole switch 10AX - 250V~ Interrupteur bipolaire 10AX-250V~ <b>Pulsador tipo rocking 10A 250V~ 24V DC</b> Rocking pushbutton 10A 250V~ 24V DC Bouton poussoir rocking 10A 250V~ 24V DC</p>	68	306	26 61	ref. 2 	1 Unidad Unit Unité
	68	308		ref. 2 	
	68	304		ref. 2 	
	68	314		ref. 2 	
	68	312		ref. 2 	
 <p><b>Doble interruptor 10AX - 250V~</b> Double switch 10AX - 250V~ Double interrupteur 10AX-250V~  <b>Doble conmutador 10AX - 250V~</b> Double two-way switch 10AX - 250V~ Double va-et-vient 10AX-250V~</p>	68	300	26 61	ref. 2 	1 Unidad Unit Unité
	68	302	26 61	ref. 2 	
 <p><b>Mecanismo para persianas 10A 250 V~ rocking (2,5 A para motores) (sin enclavamiento) su instalación requiere un dispositivo de control.</b> Electric blinds mechanism 10A 250 V~ rocking (2.5 A for motors) (without blockage system). Installation requires the use of relays. <b>Mécanisme pour volets roulants 10A 250 V~ rocking (2,5 A para motores) (sans verrouillage de sécurité) son installation requiert un dispositif de contrôle.</b></p>	68	342	26 61	ref. 2 	1 Unidad Unit Unité
 <p><b>Doble pulsador 10A - 250V~ 24V DC</b> Double pushbutton 10A - 250V~ 24V DC Double bouton poussoir 10A-250V~ - 24V DC</p>	37	343	26 61	ref. 2 	1 Unidad Unit Unité



		Serie Set Série	Código Code Cod	Acabado Finish Finition	Embalaje Packaging Emballage	
	Pulsador 10A - 250V~ 24V DC Pushbutton 10A - 250V~ 24V DC Bouton poussoir 10A-250V~ - 24V DC	37	310	26 61	ref. 2 	1 Unidad Unit Unité
	Regulador conmutador potencia 40-500W (incandescencia y halógenas) Dimmer two-way switch power 40-500W (for incandescence and halogen bulbs) Variateur - va-et-vient puissance 40-500W (incandescent et halogène)	37	332	26 61	ref. 2 	1 Unidad Unit Unité
	Regulador para motores 6A-250V~ Dimmer for motors 6A-250V~ Variateur pour moteurs 6A-250V~	37	331	26 61	ref. 2 	1 Unidad Unit Unité
	Potenciómetro regulador de volumen Potentiometer for volume regulation Potentiomètre pour réglage du volume	37	924	26 61	ref. 2 	Ver notas técnicas en pág. 110. See technical information at page 110. Voir information technique à la page 110.
	Sintonizador de radio y control de volumen Radio tuner & volume control Radio tuner et réglage du volume	37	925	26 61		



# F-37 Rocking Switches Collection

	Serie Set Série	Código Code Cod	Acabado Finish Finition	Embalaje Packaging Emballage	
	Interruptor unipolar 10AX - 250V~ One pole switch 10AX - 250V~ Interrupteur unipolaire 10AX-250V~	67 306	Ver acabados See finishes Voir finitions	ref. 2 	1 Unidad Unit Unité
	Conmutador 10AX - 250V~ Two-way switch 10AX - 250V~ Va-et-vient 10AX-250V~	67 308		ref. 2 	
	Cruzamiento 10AX - 250V~ Crossing switch 10AX - 250V~ Permutateur 10AX-250V~	67 304		ref. 2 	
	Interruptor bipolar 10AX - 250V~ Two pole switch 10AX - 250V~ Interrupteur bipolaire 10AX-250V~	67 314		ref. 2 	
	Pulsador tipo rocking 10A 250V~ 24V DC Rocking pushbutton 10A 250V~ 24V DC Bouton poussoir rocking 10A 250V~ 24V DC	67 312		ref. 2 	
	Doble interruptor 10AX - 250V~ Double switch 10AX - 250V~ Double interrupteur 10AX-250V~	67 300	Ver acabados See finishes Voir finitions	ref. 2 	1 Unidad Unit Unité
	Doble conmutador 10AX - 250V~ Double two-way switch 10AX - 250V~ Double va-et-vient 10AX-250V~	67 302		ref. 2 	
	Doble pulsador 10A - 250V~ 24V DC Rocking Double pushbutton 10A - 250V~ 24V DC Rocking Double bouton poussoir 10A-250V~ - 24V DC Rocking	67 345			
	Mecanismo para persianas 10A 250 V~ Rocking (2,5 A para motores) (sin enclavamiento) su instalación requiere un dispositivo de control.  Electric blinds mechanism 10A 250 V~ Rocking (2.5 A for motors) (without blockage system). Installation requires the use of relays.  Mécanisme pour volets roulants 10A 250 V~ Rocking (2,5 A para motores) (sans verrouillage de sécurité) son installation requiert un dispositif de contrôle.	67 342	Ver acabados See finishes Voir finitions	ref. 2 	1 Unidad Unit Unité
	Pulsador 10A - 250V~ 24V DC Pushbutton 10A - 250V~ 24V DC Bouton poussoir 10A-250V~ - 24V DC	37 310	Ver acabados See finishes Voir finitions	ref. 2 	1 Unidad Unit Unité
	Pulsador temporizador 10A 250V~ - 24V DC (30 seg. a 10 min.) (incandescencia y halógena) Timer pushbutton 10 A 250V~ - 24V DC (30 sec. to 10 min.) (incandescence and halogen) Bouton poussoir temporisateur 10A 250 - 24V DC (30 sec. A 10min.) (incandescent et halogène)	37 316			

## ACABADO FINISH FINITION



54.  
Dorado/Marrón  
Golden/Brown  
Doré/Marron





57.  
Patiné americano/Marrón  
Antique bronze/Brown  
Bronze ancien/Marron



26.  
Cromado/Blanco  
Chrome-plated/White  
Chromé/Blanc



61.  
Cromado/Metalizado  
Chrome-plated/Metallic  
Chromé/Métallisé

		Serie Set Série	Código Code Cod	Acabado Finish Finition	Embalaje Packaging Emballage	
	Doble pulsador 10A - 250V~ 24V DC Double pushbutton 10A - 250V~ 24V DC Double bouton poussoir 10A-250V~ - 24V DC	37	343	Ver acabados See finishes Voir finitions	ref. 2 	
						1 Unidad Unit Unité
	Regulador conmutador potencia 40-500W (incandescencia y halógenas) Dimmer two-way switch power 40-500W (for incandescence and halogen bulbs) Variateur - va-et-vient Puissance 40-500W (incandescent et halogène)	37	332	Ver acabados See finishes Voir finitions	ref. 2 	
						1 Unidad Unit Unité
	Regulador para motores 6A-250V~ Dimmer for motors 6A-250V~ Variateur pour moteurs 6A-250V~	37	331	Ver acabados See finishes Voir finitions	ref. 2 	
						1 Unidad Unit Unité
	Potenciómetro regulador de volumen Potentiometer for volume regulation Potentiomètre pour réglage du volume	37	924	Ver acabados See finishes Voir finitions	ref. 2 	Ver notas técnicas en pág. 106. See technical information at page 106. Voir information technique à la page 106.
	Sintonizador de radio y control de volumen Radio tuner & volume control Radio tuner et réglage du volume	37	925			
						1 Unidad Unit Unité

		Serie Set Série	Código Code Cod	Acabado Finish Finition	Embalaje Packaging Emballage	
	Interruptor unipolar 10AX - 250V~ One pole switch 10AX - 250V~ Interrupteur unipolaire 10AX-250V~	37	306	Ver acabados See finishes Voir finitions	ref. 2 	1 Unidad Unit Unité
	Conmutador 10AX - 250V~ Two-way switch 10AX - 250V~ Va-et-vient 10AX-250V~	37	308		ref. 2 	
	Cruzamiento 10AX - 250V~ Crossing switch 10AX - 250V~ Permutateur 10AX-250V~	37	304		ref. 2 	
	Interruptor bipolar 10AX - 250V~ Two pole switch 10AX - 250V~ Interrupteur bipolaire 10AX-250V~	37	314		ref. 2 	
	Doble interruptor 10AX - 250V~ Double switch 10AX - 250V~ Double interrupteur 10AX-250V~	37	300	Ver acabados See finishes Voir finitions	ref. 2 	 <ul style="list-style-type: none"> <li>0 Circuitos cerrados</li> <li>I Circuito A abierto</li> <li>II Circuito A y B abierto</li> <li>III Circuito A cerrado y B abierto</li> <li>0 Both circuits Off</li> <li>I A circuit On</li> <li>II Both circuits On</li> <li>III B circuit On, A Off</li> <li>0 Circuits fermés</li> <li>I Circuit A ouvert</li> <li>II Circuits A et B ouverts</li> <li>III Circuit B ouvert, A fermé</li> </ul> <p>302 La posición 0 varía según la posición del otro conmutador 0 position depends on the position of the other two-way switch La position 0 varie selon la position de l'autre va-et-vient</p>
	Doble conmutador 10AX - 250V~ Double two-way switch 10AX - 250V~ Double va-et-vient 10AX-250V~	37	302		ref. 2 	
	Pulsador 10A - 250V~ 24V DC Pushbutton 10A - 250V~ 24V DC Bouton poussoir 10A-250V~ - 24V DC	37	310	Ver acabados See finishes Voir finitions	ref. 2 	1 Unidad Unit Unité
	Pulsador temporizador 10A 250V~ - 24V DC (30 seg. a 10 min.) (incandescencia y halógena) Timer pushbutton 10A 250V~ - 24V DC (30 sec. to 10 min.) (incandescence and halogen) Bouton poussoir temporisateur 10A 250V~ - 24V DC (30 sec. A 10min.) (incandescent et halogène)	37	316		ref. 2 	
	Doble pulsador 10A - 250V~ 24V DC Double pushbutton 10A - 250V~ 24V DC Double bouton poussoir 10A-250V~ - 24V DC	37	343	Ver acabados See finishes Voir finitions	ref. 2 	1 Unidad Unit Unité

ACABADO FINISH FINITION



54.  
Dorado/Marrón  
Golden/Brown  
Doré/Marron



57.  
Patiné americano/Marrón  
Antique bronze/Brown  
Bronze ancien/Marron



25.  
Acero inox/Blanco  
Stainless Steel/White  
Acier inox/Blanc



51.  
Acero inox/Metalizado  
Stainless steel/Metallic  
Acier inox/Métallisé



		Serie Set Série	Código Code Cod	Acabado Finish Finition	Embalaje Packaging Emballage	
	Mecanismo para persianas 10A - 250V~ para motores 2'5 A Electric blinds mechanism 10A - 250V~ for 2.5 A motors Mécanisme pour volets roulants 10A-250V~ Pour moteurs 2.5 A	37	342	Ver acabados See finishes Voir finitions	ref. 2 	1 Unidad Unit Unité
	Mecanismo para tarjetas con indicador luminoso Card switch mechanism with luminous indicator Mécanisme pour cartes avec indicateur lumineux	37	935	05 Blanco White Blanc 03 Marrón Brown Marron	ref. 2 	Se recomienda la instalación con relés Installation with relays is recommended L'installation avec relais est recommandée
		37	936	50 Metalizado Metallic Métallisé	ref. 2 	
	Baliza luminosa 230V~ blanco-verde-rojo Luminous marker 230V~ white - green - red Balise lumineuse 230V~ blanche - verte - rouge	37	755	05 Blanco White Blanc	ref. 2 	
	Baliza luminosa 12/24V DC blanco-verde-rojo Luminous marker 12/24V DC white - green - red Balise lumineuse 12/24V DC blanche - verte - rouge	37	756	03 Marrón Brown Marron	ref. 2 	
	Baliza de emergencia 230V~ Emergency marker 230V~ Balise d'urgence 230V~	37	760	50 Metalizado Metallic Métallisé	ref. 2 	
	Base de enchufe 16A - 250V~ con obturadores de seguridad Socket outlet 2 poles without earth 16A - 250V~ with shutters Prise de courant 16A - 250V~ avec obturateurs de sécurité	37	209	05 Blanco White Blanc 03 Marrón Brown Marron 50 Metalizado Metallic Métallisé	ref. 2 	Sólo reposición Only for replacement Uniquement pour remplacement
	Base TT lateral con obturadores de seguridad 16A - 250V~ German 2 poles socket with earth 16A -250V~ with shutters Prise de courant 16A - 250V~ schuko et obturateurs de sécurité	37	212	05 Blanco White Blanc 03 Marrón Brown Marron 50 Metalizado Metallic Métallisé	ref. 2 	1 Unidad Unit Unité

		Serie Set Série	Código Code Cod	Acabado Finish Finition	Embalaje Packaging Emballage	
	Base TT sistema francés 16A - 250V~ con obturadores de seguridad French 2 pole socket with earth pin 16A - 250V~ with shutters Prise de courant 16A-250V~ avec terre française et obturateurs de sécurité	37	208	05 Blanco White Blanc 03 Marrón Brown Marron 50 Metalizado Metallic Métallisé	ref. 2 	
						1 Unidad Unit Unité
	Doble toma telefonía 6 vías 6 ways double telephone socket Double prise téléphone 6 voies	37	706	05 Blanco White Blanc 03 Marrón Brown Marron 50 Metalizado Metallic Métallisé	ref. 2 	1 línea y 2 salidas. Posibilidad de 2 líneas independientes (ver notas técnicas en pág. 109 ). 1 line and 2 ways. Possibility of 2 independent lines (see technical notes at page 109). 1 ligne, 2 sorties. Possibilité de 2 lignes indépendants. (voir notes techniques page 109)
						1 Unidad Unit Unité
	Doble toma RJ45 CAT 6 Double 6 RJ45 CAT socket Double prise RJ45 CAT6	37	707	05 Blanco White Blanc 03 Marrón Brown Marron 50 Metalizado Metallic Métallisé	ref. 2 	
	Conjunto Teléfono 6 vías + RJ45 CAT6 6 ways telephone socket + 6 RJ45 CAT Double prise téléphone 6 voies + RJ45 CAT 6	37	708	05 Blanco White Blanc 03 Marrón Brown Marron 50 Metalizado Metallic Métallisé	ref. 2 	
						1 Unidad Unit Unité
	Tomas señal R/TV y SAT ecualizada R/TV and SAT socket outlets Prises signal RTV et SAT	37	712	05 Blanco White Blanc	ref. 2 	Ver notas técnicas en pág. 107. See technical information at page 107. Voir information technique à la page 107.
	Toma única Single socket Prise unique Intermedia A Intermediate A Intermède A Intermedia B Intermediate B Intermède B Toma final Final socket Prise finale Sólo tapa Only cover Seulement couvercle	37	713	03 Marrón Brown Marron	ref. 2 	
		37	714	50 Metalizado Metallic Métallisé	ref. 2 	
		37	711		ref. 2 	
		37	715		ref. 2 	
						1 Unidad Unit Unité

		Serie Set Série	Código Code Cod	Acabado Finish Finition	Embalaje Packaging Emballage	
	Regulador conmutador potencia 40-500W (incandescencia y halógenas) Dimmer two-way switch power 40-500W (for incandescence and halogen bulbs) Variateur - va-et-vient Puissance 40-500W (incandescent et halogène)	37	332	Ver acabados See finishes Voir finitions	ref. 2 	Ver notas técnicas en pág. 106. See technical information at page 106. Voir information technique à la page 106.
	Regulador para motores 6A-250V~ Dimmer for motors 6A-250V~ Variateur pour moteurs 6A-250V~	37	331	Ver acabados See finishes Voir finitions	ref. 2 	
	Termostato para calefacción suelo radiante, incluye sonda Floor heating thermostat with sensor cable Thermostat pour chauffage sol radiant, avec sonde	37	721	05 Blanco White Blanc	ref. 2 	1 Unidad Unit Unité
	Termostato para calefacción temperatura ambiente Room temperature thermostat Thermostat chauffage température d'ambiance	37	722		ref. 2 	
	Detector de presencia 180º y sonido Presence and sound detector 180º Détecteur de présence et son 180º	37	750	05 Blanco White Blanc 50 Metalizado Metallic Métallisé	ref. 2 	1 Unidad Unit Unité

ACABADO FINISH FINITION



54.  
Dorado/Marrón  
Golden/Brown  
Doré/Marron



57.  
Patiné americano/Marrón  
Antique bronze/Brown  
Bronze ancien/Marron













25.  
Acero inox/Blanco  
Stainless Steel/White  
Acier inox/Blanc



51.  
Acero inox/Metalizado  
Stainless steel/Metallic  
Acier inox/Métallisé



		Serie Set Série	Código Code Cod	Acabado Finish Finition	Embalaje Packaging Emballage	
	Carátula para salida de cables Cable outlet cover Couvercle pour sortie de câbles	37	927	05 Blanco White Blanc 03 Marrón Brown Marron 50 Metalizado Metallic Métallisé	ref. 2 	1 Unidad Unit Unité
	Placa ciega Blind cover Couvercle neutre	37	656	05 Blanco White Blanc 03 Marrón Brown Marron 50 Metalizado Metallic Métallisé	ref. 2 	1 Unidad Unit Unité
	Potenciómetro regulador de volumen Potentiometer for volume regulation Potentiomètre pour réglage du volume	37	924	Ver acabados See finishes Voir finitions	ref. 2 	Ver notas técnicas en pág. 110. See technical notes at page 110. Voir l'information technique sur page 110. 1 Unidad Unit Unité
	Sintonizador de radio y control de volumen Radio tuner & volume control Radio tuner et réglage du volume	37	925	Ver acabados See finishes Voir finitions	ref. 2 	1 Unidad Unit Unité
	Altavoz para caja universal Potencia 2W Impedancia 16 Ω Loudspeaker for universal box Power 2W Impedance 16 Ω Hautparleur pour boîtier standard Puissance 2W - impédance 16 Ω	37	926	05 Blanco White Blanc 03 Marrón Brown Marron 50 Metalizado Metallic Métallisé	ref. 2 	Ver notas técnicas en pág. 110. See technical notes at page 110. Voir l'information technique sur page 110. 1 Unidad Unit Unité

ACABADO FINISH FINITION



54.  
Dorado/Marrón  
Golden/Brown  
Doré/Marron



57.  
Patiné americano/Marrón  
Antique bronze/Brown  
Bronze ancien/Marron











25.  
Acero inox/Blanco  
Stainless Steel/White  
Acier inox/Blanc



51.  
Acero inox/Metalizado  
Stainless steel/Metallic  
Acier inox/Métallisé

		Serie Set Série	Código Code Cod	Acabado Finish Finition	Embalaje Packaging Emballage	
	Toma para altavoz 2 salidas Loudspeaker socket 2 ways Prise pour hautparleur 2 sorties	37	905	05 Blanco White Blanc 03 Marrón Brown Marron 50 Metalizado Metallic Métallisé	ref. 2 	1 Unidad Unit Unité
	Adaptador para controles de sonido EGI® Adaptor for EGI® sound controls Adaptateur pour contrôles de son EGI®	37	944	05 Blanco White Blanc 10 Negro Black Noir	ref. 2 	1 Unidad Unit Unité
	Adaptador para controles de sonido TEZ® y Sonbel® Adaptor for TEZ® and Sonbel® sound controls Adaptateur pour contrôles de son TEZ® et Sonbel®	37	945	05 Blanco White Blanc 10 Negro Black Noir	ref. 2 	1 Unidad Unit Unité
	Zumbador 220V 80dB intermitente Buzzer 220V 80dB intermittent Sonnnette 220V 80dB intermittent	37	390	05 Blanco White Blanc 03 Marrón Brown Marron 50 Metalizado Metallic Métallisé	ref. 2 	Ver notas técnicas en pág. 105. See technical information at page 105. Voir information technique à la page 105. 1 Unidad Unit Unité

		Serie Set Série	Código Code Cod	Acabado Finish Finition	Embalaje Packaging Emballage	
	Marco madera 1 elemento 1 element wood frame Plaque en bois 1 élément 90x90x11mm	37	801	Ver acabados See finishes Voir finitions	ref. 2 	1 Unidad Unit Unité
	Marco madera 2 elementos 2 elements wood frame Plaque en bois 2 éléments 90x162x11mm	37	802	Ver acabados See finishes Voir finitions	ref. 2 	1 Unidad Unit Unité
	Marco madera 3 elementos 3 elements wood frame Plaque en bois 3 éléments 90x233x11mm	37	803	Ver acabados See finishes Voir finitions	ref. 2 	1 Unidad Unit Unité
	Marco madera 4 elementos 4 elements wood frame Plaque en bois 4 éléments 90x299x11mm	37	804	Ver acabados See finishes Voir finitions	ref. 2 	1 Unidad Unit Unité

ACABADO FINISH FINITION



04.  
Wenge  
Wengue  
Wengué









03.  
Tabacco  
Tobacco  
Tabac



02.  
Cerezo  
Cherry tree  
Merisier



		Serie Set Série	Código Code Cod	Acabado Finish Finition	Embalaje Packaging Emballage	
	Marco cristal 1 elemento 1 element glass frame Plaque en verre 1 élément 90x90x12mm	37	801	Ver acabados See finishes Voir finitions	ref. 2 	1 Unidad Unit Unité
	Marco cristal 2 elementos 2 elements glass frame Plaque en verre 2 éléments 90x162x12mm	37	802	Ver acabados See finishes Voir finitions	ref. 2 	1 Unidad Unit Unité
	Marco cristal 3 elementos 3 elements glass frame Plaque en verre 3 éléments 90x233x12mm	37	803	Ver acabados See finishes Voir finitions	ref. 2 	1 Unidad Unit Unité



07.  
Azul Reflex  
Reflex Blue  
Bleu reflex



66.  
Blanco  
White  
Blanc



66.  
Verde Manzana  
Apple Green  
Vert pomme



www.tesli.com

www.tesli.com

www.tesli.com

**Interiorismo: Carmen Barasona**  
*Interior Design: Carmen Barasona*  
*Architecture d'intérieur: Carmen Barasona*



# Venezia Rocking and Rotary switches Collection



Interiorismo: Pepe Leal – Fotografía: Benjamín Alcázar  
Interior Design: Pepe Leal – Photography: Benjamín Alcázar  
Architecture d'intérieur: Pepe Leal – Photographie: Benjamín Alcázar

**Instalación empotrada.**  
**Mecanismos de 10AX - 250V~**  
**Bases de enchufe de 16A -250V~**  
**Contactos de plata de alto poder de ruptura.**  
**Marcos de madera, latón y porcelana.**  
**Marcos para instalar en posición vertical u horizontal.**  
**Instalación en caja universal con tornillos.**

Fitting installation.  
10AX - 250V~ mechanisms.  
10/16A - 250V~ earthing sockets.  
Silver contacts with high breaking power.  
Wooden, brass & porcelain frames.  
Frames for vertical or horizontal installations.  
Installation in standard box with screws.

*Installation encastrée.*  
*Mécanismes de 10A - 250V~*  
*Prises de courant 10/16A - 250V ~*  
*Contacts d'argent avec haut pouvoir de rupture.*  
*Plaques en bois, laiton et porcelaine.*  
*Plaques pour installation verticale ou horizontale.*  
*Installation sur boîte standard avec vis.*

# VENEZIA ROCKING SWITCHES



**Manecilla patiné americano, carátula cuadrada marrón, marco latón patiné americano**

Antique bronze key, square brown cover, antique bronze brass frame

*Manette bronze ancien, intérieur carré marron, plaque laiton bronze ancien*



**Manecilla cromada cuadrada, carátula cuadrada metalizada, marco latón níquel satinado**

Square chrome-plated key, square metallic cover, satin nickel-plated brass frame

*Manette chromée carrée, intérieur carré métallisé, plaque laiton niquel satiné*



**Manecilla patiné americano, carátula redonda marrón, marco latón cobre antiguo**

Antique bronze key, round brown cover, antique cooper brass frame

*Manette bronze ancien, intérieur rond marron, plaque laiton cuivre ancien*





**Manecilla dorada, carátula redonda blanca, marco madera Oval nogal**

Golden key, round white cover, Oval walnut colored beech wood frame

*Manette dorée, intérieur rond blanc, plaque bois Oval hêtre couleur noyer*



**Manecilla patiné americano, carátula redonda blanca, marco madera Clásica sapelly**

Antique bronze key, round white cover, Clásica sapelly wood frame

*Manette bronze ancien, intérieur rond blanc, plaque bois Clásica sapelly*



**Manecilla cromada, carátula redonda blanca, marco madera Carré sapelly**

Chrome-plated key, round white cover, Carré sapelly wood frame

*Manette chromée, intérieur rond blanc, plaque bois Carré sapelly*

# VENEZIA ROTARY SWITCHES



**Lazo dorado, carátula cuadrada marrón, marco latón dorado**

Golden knob, square brown cover, golden brass frame

*Bouton doré, intérieur carré blanc, plaque laiton dorée*



**Lazo patiné americano, carátula redonda marrón, marco latón patiné cobre**

Antique bronze knob, round brown cover, patinated copper brass frame

*Bouton bronze ancien, intérieur rond marron, plaque laiton patiné cuivre*



**Lazo madera, carátula redonda blanca, marco madera Carré sapelly**

Wood knob, round white cover, Carré sapelly wood frame

*Bouton bois, intérieur rond blanc, plaque bois Carré sapelly*



**Lazo oro, carátula redonda blanca, marco madera Toscana nogal**

Golden knob, round white cover, Toscana walnut colored beech wood frame

*Bouton doré, intérieur rond blanc, plaque bois Toscana hêtre couleur noyer*



**Lazo dorado, carátula redonda blanca, marco madera verde - dorado**

Golden knob, round white cover, green-gold wood frame

*Bouton doré, intérieur rond blanc, plaque bois vert - doré*















**Lazo porcelana blanca, carátula redonda blanca, marco madera gris - dorado**

White porcelain knob, round white cover, grey - gold wood frame

*Bouton porcelaine blanche, intérieur rond blanc, plaque bois gris - doré*



# Venezia Rocking Switches Collection

	Descripción	Serie Set Série	Código Code Cod	Acabado Finish Finition	Embalaje Packaging Emballage	
	<b>Interruptor unipolar 10AX - 250V~</b> One pole switch 10AX - 250V~ Interrupteur unipolaire 10AX-250V~ <b>Conmutador 10AX - 250V~</b> Two-way switch 10AX - 250V~ Va-et-vient 10AX-250V~ <b>Cruzamiento 10AX - 250V~</b> Crossing switch 10AX - 250V~ Permutateur 10AX-250V~ <b>Interruptor bipolar 10AX - 250V~</b> Two pole switch 10AX - 250V~ Interrupteur bipolaire 10AX-250V~ <b>Pulsador Rocking 10A - 250V ~ 24V DC</b> Rocking Pushbutton 10A - 250V~ 24V DC Bouton poussoir Rocking 10A-250V~ - 24V DC	65	306	Ver acabados See finishes Voir finitions	ref. 2 	1 Unidad Unit Unité
		65	308		ref. 2 	
		65	304		ref. 2 	
		65	312		ref. 2 	
					ref. 2 	
	<b>Doble interruptor 10AX - 250V~</b> Double switch 10AX - 250V~ Double interrupteur 10AX-250V~  <b>Doble conmutador 10AX - 250V~</b> Double two-way switch 10AX - 250V~ Double va-et-vient 10AX-250V~  <b>Doble pulsador Rocking 10A - 250V~ 24V DC</b> Rocking Double pushbutton 10A - 250V~ 24V DC Double bouton poussoir Rocking 10A-250V~ - 24V DC	65	300	Ver acabados See finishes Voir finitions	ref. 2 	1 Unidad Unit Unité
		65	302		ref. 2 	
		65	345		ref. 2 	
	<b>Mecanismo para persianas 10A 250 V~ Rocking</b> (2,5 A para motores) (sin enclavamiento) su instalación requiere un dispositivo de control. Electric blinds mechanism 10A 250 V~ Rocking (2.5 A for motors) (without blockage system). Installation requires the use of relays. <b>Mécanisme pour volets roulants 10A 250 V~ Rocking</b> (2,5 A para motores) (sans verrouillage de sécurité) son installation requiert un dispositif de contrôle.	65	342	Ver acabados See finishes Voir finitions	ref. 2 	1 Unidad Unit Unité

Mecanismos combinables con marcos y accesorios Venezia  
 Mechanisms are combinable with Venezia frames and accessories  
 Mécanismes combinables avec cadres et accessoires Venezia

## ACABADO FINISH FINITION



30.  
Dorado/Blanco  
Gold/White  
Doré/Blanc



59.  
Patiné/Blanco  
Antique bronze/White  
Bronze ancien/Blanc



26.  
Cromado/Blanco  
Chrome-plated/White  
Chromé/Blanc



54.  
Dorado/Marrón  
Gold/Brown  
Doré/Marron



57.  
Patiné/Marrón  
Antique bronze/Brown  
Patiné/Marron









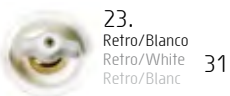
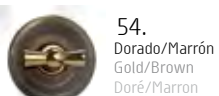
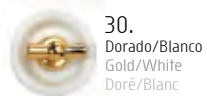





52.  
Cromado/Marrón  
Chrome-plated/Brown  
Chromé/Marron



	Serie Set Série	Código Code Cod	Acabado Finish Finition	Embalaje Packaging Emballage	
	35	306	Ver acabados See finishes Voir finitions	ref. 2 	<p>1 Unidad Unit Unité</p>
	35	308		ref. 2 	
	35	304		ref. 2 	
	35	314		ref. 2 	
	35	300	Ver acabados See finishes Voir finitions	ref. 2 	 <p>0 Circuitos cerrados I Circuito A abierto II Circuito A y B abierto III Circuito A cerrado y B abierto 0 Both circuits Off I A circuit On II Both circuits On III B circuit On, A Off 0 Circuits fermés I Circuit A ouvert II Circuits A et B ouverts III Circuit B ouvert, A fermé</p> <p>302 La posición 0 varía según la posición del otro conmutador Position 0 depends on the position of the other two-way switch La position 0 varie selon la position de l'autre va-et-vient</p> <p>1 Unidad Unit Unité</p>
	35	302		ref. 2 	
	35	310	Ver acabados See finishes Voir finitions	ref. 2 	<p>1 Unidad Unit Unité</p>
	35	316		ref. 2 	
	35	343	Ver acabados See finishes Voir finitions	ref. 2 	<p>1 Unidad Unit Unité</p>



		Serie Set Série	Código Code Cod	Acabado Finish Finition	Embalaje Packaging Emballage	
	Mecanismo para persianas para motores 1'66A Electric blinds mechanism for 1.66 A motors Mécanisme pour volets roulants 10A-250V~ Pour moteurs 1'66A	35	342	Ver acabados See finishes Voir finitions	ref. 2 	1 Unidad Unit Unité
	Mecanismo para tarjetas con indicador luminoso Card switch mechanism with luminous indicator Mécanisme pour cartes avec indicateur lumineux	37	935	05 Blanco White Blanc 03 Marrón Brown Marron	ref. 2 	Se recomienda la instalación con relés Installation with relays is recommended L'installation avec relais est recommandée
		37	936		ref. 2 	
	Baliza luminosa 230V~ blanco-verde-rojo Luminous marker 230V~ white - green - red Balise lumineuse 230V~ blanche - verte - rouge	35	755	05 Blanco White Blanc	ref. 2 	1 Unidad Unit Unité
	Baliza luminosa 12/24V DC blanco-verde-rojo Luminous marker 12/24V DC white - green - red Balise lumineuse 12/24V DC blanche - verte - rouge	35	756	03 Marrón Brown Marron	ref. 2 	
	Baliza de emergencia 230V~ Emergency marker 230V~ Balise d'urgence 230V~	35	760		ref. 2 	
	Base de enchufe 16A - 250V~ con obturadores de seguridad Socket outlet 2 pole without earth 16A - 250V~ with shutters Prise de courant 16A - 250V~ avec obturateurs de sécurité	35	209	05 Blanco White Blanc 03 Marrón Brown Marron	ref. 2 	Sólo reposición Only for replacement Uniquement pour remplacement
	Base TT lateral con obturadores de seguridad 16A - 250V~ German 2 pole socket with Earth 16A -250V~ with shutters Prise de courant 16A - 250V~ schuko et obturateurs de sécurité	35	212	05 Blanco White Blanc 03 Marrón Brown Marron	ref. 2 	1 Unidad Unit Unité

ACABADO FINISH FINITION



59.  
Patiné/Blanco  
Antique bronze/White  
Bronze ancien/Blanc



57.  
Patiné/Marrón  
Antique bronze/Brown  
Bronze ancien/Marron















25.  
Niquelado/Blanco  
Nickel-plated/White  
Niquelè/Blanc











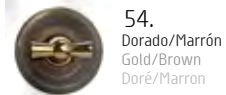
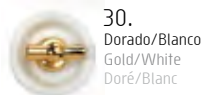

52.  
Niquelado/Marrón  
Nickel-plated/Brown  
Niquelè/Marron



23.  
Retro/Blanco  
Retro/White  
Retro/Blanc

		Serie Set Série	Código Code Cod	Acabado Finish Finition	Embalaje Packaging Emballage	
	Base TT sistema francés 16A - 250V~ con obturadores de seguridad French 2 poles socket with earth pin 16A - 250V~ with shutters Prise de courant 16A-250V~ française et obturateurs de sécurité	35	208	05 Blanco White Blanc 03 Marrón Brown Marron	ref. 2 	1 Unidad Unit Unité
	Doble toma telefonía 6 vías 6 ways double telephone socket Double prise téléphone 6 voies	35	706	05 Blanco White Blanc 03 Marrón Brown Marron	ref. 2 	1 Unidad Unit Unité
	Doble toma RJ45 CAT6 Double socket 6 RJ45 CAT Double prise RJ45 CAT6	35	707	05 Blanco White Blanc 03 Marrón Brown Marron	ref. 2 	1 Unidad Unit Unité
	Conjunto Teléfono 6 vías + RJ45 CAT6 6 ways telephone + 6 RJ45 CAT socket Double prise téléphone 6 voies + RJ45 CAT 6	35	708			
	Toma única Single socket Prise unique	35	712	05 Blanco White Blanc	ref. 2 	Ver notas técnicas en pág. 107. See technical information at page 107. Voir information technique à la page 107.
	Intermedia A Intermediate A Intermédiaire A	35	713	03 Marrón Brown Marron	ref. 2 	
	Intermedia B Intermediate B Intermédiaire B	35	714		ref. 2 	
	Toma final Final socket Prise finale	35	711		ref. 2 	
	Sólo tapa Only cover Seulement couvercle	35	715		ref. 2 	



	Serie Set Série	Código Code Cod	Acabado Finish Finition	Embalaje Packaging Emballage	
 <p>Regulador conmutador potencia 40-500W (incandescencia y halógenas) Dimmer two-way switch power 40-500W (for incandescence and halogen bulbs) Variateur - va-et-vient Puissance 40-500W (incandescent et halogène)</p>	35	332	05 Blanco White Blanc 03 Marrón Brown Marron	ref. 2 	Ver notas técnicas en pág. 104. See technical information at page 104. Voir information technique à la page 104.
 <p>Regulador para motores 6A-250V~ Dimmer for motors 6A-250V~ Variateur pour moteurs 6A-250V~</p>	35	331	05 Blanco White Blanc 03 Marrón Brown Marron	ref. 2 	
 <p>Termostato para calefacción suelo radiante, incluye sonda Floor heating thermostat with sensor cable. Thermostat pour chauffage sol radiant, avec sonde</p>	37	721	05 Blanco White Blanc	ref. 2 	Instalar solamente en marco especial para elementos cuadrados ref. 35-821., 36-821., 36-831., 38-821., 31-821.. Install only on special frame for square elements ref. 35-821., 36-821., 36-831., 38-821., 31-821.. À installer seulement sur plaque spéciale pour éléments carrés réf. 35-821., 36-821., 36-831., 38-821., 31-821..
 <p>Termostato para calefacción temperatura ambiente Room temperature thermostat Thermostat chauffage temperature d'ambiance</p>	37	722		ref. 2 	
 <p>Detector de presencia 180° y sonido Presence and sound detector 180° Déflecteur de présence et son 180°</p>	37	750	05 Blanco White Blanc 50 Metalizado Metallic Métallisé	ref. 2 	Instalar solamente en marco especial para elementos cuadrados ref. 35-821., 36-821., 36-831., 38-821., 31-821.. Install only on special frame for square elements ref. 35-821., 36-821., 36-831., 38-821., 31-821.. À installer seulement sur plaque spéciale pour éléments carrés réf. 35-821., 36-821., 36-831., 38-821., 31-821..

| 1 Unidad Unit Unité

| 1 Unidad Unit Unité

| 1 Unidad Unit Unité

| 1 Unidad Unit Unité

ACABADO FINISH FINITION



59.  
Patiné/Blanco  
Antique bronze/White  
Bronze ancien/Blanc



57.  
Patiné/Marrón  
Antique bronze/Brown  
Bronze ancien/Marron



25.  
Niquelado/Blanco  
Nickel-plated/White  
Niquelé/Blanc





52.  
Niquelado/Marrón  
Nickel-plated/Brown  
Niquelé/Marron



23.  
Retro/Blanco  
Retro/White  
Retro/Blanc



		Serie Set Série	Código Code Cod	Acabado Finish Finition	Embalaje Packaging Emballage	
	Mecanismo interruptor con llave Switch mechanism with key Interrupteur à clés	35	906	05 Blanco White Blanc 03 Marrón Brown Marron	ref. 2 	1 Unidad Unit Unité
	Carátula para salida de cables Cable outlet cover Couvercle pour sortie de câbles	35	927	Ver acabados See finishes Voir finitions	ref. 2 	1 Unidad Unit Unité
	Placa ciega Blind cover Couvercle neutre	35	656	05 Blanco White Blanc 03 Marrón Brown Marron	ref. 2 	1 Unidad Unit Unité
	Potenciómetro regulador de volumen Potentiometer for volume regulation Potentiomètre pour réglage du volume	35	924	05 Blanco White Blanc 03 Marrón Brown Marron	ref. 2 	1 Unidad Unit Unité
					Ver notas técnicas en pág. 110. See technical information at page 110. Voir information technique à la page 110.	1 Unidad Unit Unité

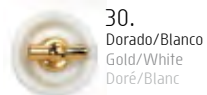

30.  
Dorado/Blanco  
Gold/White  
Doré/Blanc









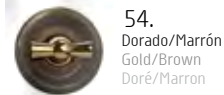

16.  
Madera/Blanco  
Wood/White  
Bois/Blanc



17.  
Porcelana/Blanco  
Porcelain/White  
Porcelaine/Blanc



54.  
Dorado/Marrón  
Gold/Brown  
Doré/Marron











		Serie Set Série	Código Code Cod	Acabado Finish Finition	Embalaje Packaging Emballage	
	Sintonizador de radio y control de volumen Radio tuner and volume regulator Radio tuner et réglage du volume	35	925	05 Blanco White Blanc 03 Marrón Brown Marron	ref. 2 	Ver notas técnicas en pág. 110. See technical information at page 110. Voir information technique à la page 110.
	Altavoz para caja universal Potencia 2W Impedancia 16Ω Loudspeaker for universal box Power 2W Impedance 16Ω Hautparleur pour boîtier standard Puissance 2W - impédance 16Ω	35	926	05 Blanco White Blanc 03 Marrón Brown Marron	ref. 2 	Ver notas técnicas en pág. 110. See technical information at page 110. Voir information technique à la page 110.
	Toma para altavoz Loudspeaker socket Prise pour hautparleur	35	905	05 Blanco White Blanc 03 Marrón Brown Marron	ref. 2 	
	Zumbador 220V 80 dB intermitente Buzzer 220V 80dB intermittent Sonnnette 220V 80dB intermitente	35	390	05 Blanco White Blanc 03 Marrón Brown Marron	ref. 2 	

1 Unidad Unit Unité

1 Unidad Unit Unité

1 Unidad Unit Unité

1 Unidad Unit Unité

	Serie Set Série	Código Code Cod	Acabado Finish Finition	Embalaje Packaging Emballage	
 	Marco 1 elemento 1 element frame Plaque 1 élément 125x85x13 mm	35	801	Ver acabados See finishes Voir finitions	ref. 2 
	Marco especial para 1 elemento cuadrado (a usar con refs 37 721., 37 722., 37 750.) Special frame for 1 square element (use with refs 37 721., 37 722., 37 750.) Plaque spéciale pour 1 élément carré (utiliser avec refs 37 721., 37 722., 37 750.)	35	821	Ver acabados See finishes Voir finitions	ref. 2 
	Marco 2 elementos 2 elements frame Plaque 2 éléments 190x85x13 mm	35	802	Ver acabados See finishes Voir finitions	ref. 2 
	Marco 3 elementos 3 elements frame Plaque 3 éléments 261,5x85x13 mm	35	803	Ver acabados See finishes Voir finitions	ref. 2 
	Marco 4 elementos 4 elements frame Plaque 4 éléments 333x85x13 mm	35	804	Ver acabados See finishes Voir finitions	ref. 2 

1 Unidad Unit Unité

1 Unidad Unit Unité

Possibilidad de personalización de los marcos en acabado crudo  
Possible custom-made finishes with natural wood frames  
Possibilité de personnaliser les plaques en bois naturel

1 Unidad Unit Unité

Los marcos de madera sapelly son trabajados artesanalmente. Tratados con barniz incoloro mantienen toda su belleza natural. Cada pieza, exclusiva en si misma, nunca presentará la uniformidad de un producto plástico. Es única y diferente en función del corte de la madera y sus vetas. Sapelly wood frames are traditional finished. Treated with colourless varnish they keep their natural beauty. Each piece is exclusive and never presents the same evenness as a plastic product. It is unique and different depending on the wood cut and its wood grain.  
Les plaques de bois sapelly sont artisanales. Traitées à l'aide d'un vernis incolore, elles maintiennent toute leur beauté naturelle. Chaque pièce est unique et ne pourra jamais présenter l'uniformité d'un produit plastique. Ces pièces sont uniques et chacune différente en fonction de la coupe du bois et de ses veines.

1 Unidad Unit Unité

ACABADO FINISH FINITION



20.  
Haya Color Nogal  
Beech Walnut Colored  
Hêtre Couleur noyer



16.  
Sapelly  
Sapelly  
sapelly













15.  
Haya Color Roble  
Beech Oak Colored  
Hêtre couleur chêne



00.  
Haya Crudo  
Natural Beech  
Hêtre brut



05.  
Haya Lacado Blanco  
Beech White lacquered  
Hêtre Laqué Blanc

		Serie Set Série	Código Code Cod	Acabado Finish Finition	Embalaje Packaging Emballage	
 	Marco 1 elemento 1 element frame Plaque 1 élément 110x85x12 mm	36	801	Ver acabados See finishes Voir finitions	ref. 2 	
	Marco especial para 1 elemento cuadrado (a usar con refs 37 721., 37 722., 37 750..) Special frame for 1 square element (use with refs 37 721., 37 722., 37 750..) Plaque spéciale pour 1 élément carré (utiliser avec refs 37 721., 37 722., 37 750..)	36	821		ref. 2 	
	Marco 2 elementos 2 elements frame Plaque 2 éléments 181x85x12 mm	36	802	Ver acabados See finishes Voir finitions	ref. 2 	
	Marco 3 elementos 3 elements frame Plaque 3 éléments 253x85x12 mm	36	803	Ver acabados See finishes Voir finitions	ref. 2 	Posibilidad de personalización de los marcos en acabado crudo Possible custom-made finishes with natural wood frames Possibilité de personnaliser les plaques en bois naturel
	Marco 4 elementos 4 elements frame Plaque 4 éléments 324x85x12mm	36	804	Ver acabados See finishes Voir finitions	ref. 2 	Los marcos de madera sapelly son trabajados artesanalmente. Tratados con barniz incoloro mantienen toda su belleza natural. Cada pieza, exclusiva en si misma, nunca presentará la uniformidad de un producto plástico. Es única y diferente en función del corte de la madera y sus vetas. Sapelly wood frames are traditional finished. Treated with colourless varnish they keep their natural beauty. Each piece is exclusive and never presents the same evenness as a plastic product. It is unique and different depending on the wood cut and its wood grain. Les plaques de bois sapelly sont artisanales. Traitées à l'aide d'un vernis incolore, elles maintiennent toute leur beauté naturelle. Chaque pièce est unique et ne pourra jamais présenter l'uniformité d'un produit plastique. Ces pièces sont uniques et chacune différente en fonction de la coupe du bois et de ses veines.

1 Unidad Unit Unité

1 Unidad Unit Unité

1 Unidad Unit Unité

1 Unidad Unit Unité

ACABADO FINISH FINITION













16.  
Sapelly  
Sapelly  
Sapelly



00.  
Haya Crudo  
Natural Beech  
Hêtre brut



	Serie Set Série	Código Code Cod	Acabado Finish Finition	Embalaje Packaging Emballage	
 	36	811	Ver acabados See finishes Voir finitions	ref. 2 	
	36	831		ref. 2 	
	36	812	Ver acabados See finishes Voir finitions	ref. 2 	1 Unidad Unit Unité
	36	813	Ver acabados See finishes Voir finitions	ref. 2 	Posibilidad de personalización de los marcos en acabado crudo Possible custom-made finishes with natural wood frames Possibilité de personnaliser les plaques en bois naturel
	36	814	Ver acabados See finishes Voir finitions	ref. 2 	Los marcos de madera sapelly son trabajados artesanalmente. Tratados con barniz incoloro mantienen toda su belleza natural. Cada pieza, exclusiva en sí misma, nunca presentará la uniformidad de un producto plástico. Es única y diferente en función del corte de la madera y sus vetas. Sapelly wood frames are traditional finished. Treated with colourless varnish they keep their natural beauty. Each piece is exclusive and never presents the same evenness as a plastic product. It is unique and different depending on the wood cut and its wood grain. Les plaques de bois sapelly sont artisanales. Traitées à l'aide d'un vernis incolore, elles maintiennent toute leur beauté naturelle. Chaque pièce est unique et ne pourra jamais présenter l'uniformité d'un produit plastique. Ces pièces sont uniques et chacune différente en fonction de la coupe du bois et de ses veines.









ACABADO FINISH FINITION













16.  
Sapelly  
Sapelly



00.  
Haya Crudo  
Natural Beech  
Hêtre brut

	Serie Set Série	Código Code Cod	Acabado Finish Finition	Embalaje Packaging Emballage	
	38	801	20 00	ref. 2 	
	38	821	20 00	ref. 2 	
	38	802	20 00	ref. 2 	1 Unidad Unit Unité
	38	803	20 00	ref. 2 	1 Unidad Unit Unité
	38	804	20 00	ref. 2 	<p>Posibilidad de personalización de los marcos en acabado crudo Possible custom-made finishes with natural wood frames Possibilité de personnaliser les plaques en bois naturel</p>



	Serie Set Série	Código Code Cod	Acabado Finish Finition	Embalaje Packaging Emballage	
 	31	801	Ver acabados See finishes Voir finitions	ref. 2 	
	31	821		ref. 2 	
	31	802	Ver acabados See finishes Voir finitions	ref. 2 	
	31	803	Ver acabados See finishes Voir finitions	ref. 2 	Posibilidad de personalización de los marcos en acabado crudo Possible custom-made finishes with natural wood frames Possibilité de personnaliser les plaques en bois naturel
	31	804	Ver acabados See finishes Voir finitions	ref. 2 	Los marcos de madera sapelly son trabajados artesanalmente. Tratados con barniz incoloro mantienen toda su belleza natural. Cada pieza, exclusiva en sí misma, nunca presentará la uniformidad de un producto plástico. Es única y diferente en función del corte de la madera y sus vetas. Sapelly wood frames are traditional finished. Treated with colourless varnish they keep their natural beauty. Each piece is exclusive and never presents the same evenness as a plastic product. It is unique and different depending on the wood cut and its wood grain. Les plaques de bois sapelly sont artisanales. Traitées à l'aide d'un vernis incolore, elles maintiennent toute leur beauté naturelle. Chaque pièce est unique et ne pourra jamais présenter l'uniformité d'un produit plastique. Ces pièces sont uniques et chacune différente en fonction de la coupe du bois et de ses veines.

1 Unidad Unit Unité

1 Unidad Unit Unité

1 Unidad Unit Unité

1 Unidad Unit Unité

ACABADO FINISH FINITION

- 

19.  
Madera miel  
Honey wood  
Bois miel
- 

21.  
Madera envejecida  
Old wood  
Bois vieilli
- 







00.  
Madera cruda  
Natural beech wood  
Bois cru
- 

33.  
Madera verde dorado  
Green-gold wood  
Bois vert doré
- 

35.  
Madera Blanco Azul  
White-blue wood  
Bois blanc bleu
- 

34.  
Madera Negro-plateado  
Black silver-plated wood  
Bois noir argenté
- 

36.  
Madera gris dorado  
Grey-gold wood  
Bois gris doré

	Serie Set Série	Código Code Cod	Acabado Finish Finition	Embalaje Packaging Emballage	
	31	801	Ver acabados See finishes Voir finitions	ref. 2 	
	31	821			1 Unidad Unit Unité
	31	802	Ver acabados See finishes Voir finitions	ref. 2 	
					1 Unidad Unit Unité
	31	803	Ver acabados See finishes Voir finitions	ref. 2 	
					1 Unidad Unit Unité

ACABADO FINISH FINITION



11.  
Porcelana decor  
Decor porcelain  
Porcelaine décorée



17.  
Porcelana blanca  
White porcelain  
Porcelaine blanche











09.  
Porcelana craquelé  
Craquelé porcelain  
Porcelaine craquelée



27.  
Porcelana negra  
Black porcelain  
Porcelaine noire



	Serie Set Série	Código Code Cod	Acabado Finish Finition	Embalaje Packaging Emballage	
	Marco 1 elemento 1 element frame Plaque 1 élément 125x91x12 mm	39	801	Ver acabados See finishes Voir finitions	ref. 2 
	Marco 2 elementos 2 elements frame Plaque 2 éléments 181,5x91x12 mm	39	802	Ver acabados See finishes Voir finitions	ref. 2 
	Marco 3 elementos 3 elements frame Plaque 3 éléments 253x91x12 mm	39	803	Ver acabados See finishes Voir finitions	ref. 2 
	Marco 4 elementos 4 elements frame Plaque 4 éléments 324x91x12 mm	39	804	Ver acabados See finishes Voir finitions	ref. 2 

| 1 Unidad Unit Unité

| 1 Unidad Unit Unité

| 1 Unidad Unit Unité

| 1 Unidad Unit Unité

ACABADO FINISH FINITION



50.  
Dorado  
Golden  
Doré



53.  
Patiné americano  
Antique bronze  
Bronze ancien



51.  
Niquel satinado  
Satin nickel-plated  
Niquel satiné



62.  
Patiné cobre  
Patinated cooper  
Patiné cuivre



46.  
Cobre antiguo  
Antique cooper  
Cuivre ancien



49.  
Antracita  
Anthracite  
Anthracite



**Nuevo mecanismo Rotary F-37 + Nuevo marco Venezia metal (para F-37)**  
New F-37 Rotary mechanism + New Venezia metal frame (for F-37)  
Nouveau mécanisme Rotary F-37 + Nouvelle plaque Venezia métal (pour F-37)

## **Nuevos marcos Venezia Metal para instalar con mecanismos y accesorios F-37 Rocking & Rotary**









**Nota importante: Estos marcos no pueden instalarse con los mecanismos y accesorios de la serie Venezia (carátula redonda). Sólo pueden instalarse con las referencias que aparecen en las páginas 12-21 (F-37 carátula cuadrada).**

New metal Venezia frames to install with F-37 mechanisms and accessories, Rocking and Rotary systems

Important note: These frames can not be installed with the mechanisms and accessories of the Venezia collection (round cover). They only can be installed with the references that appear on the pages 12-21 (F-37 square cover).

*Nouvelles plaques Venezia Métal à installer avec les mécanismes et accessoires F37 Rocking & Rotary*

*Important : Ces plaques ne peuvent pas être installées avec les mécanismes et accessoires de la gamme Venezia (intérieur rond). Installation seulement possible avec les références qui apparaissent aux pages 12-21 (F37 intérieur carré).*

	Serie Set Série	Código Code Cod	Acabado Finish Finition	Embalaje Packaging Emballage	
 <p>Marco 1 elemento 1 element frame Plaque 1 élément 125x91x12 mm</p>	39	821	Ver acabados See finishes Voir finitions	ref. 2 	1 Unidad Unit Unité
 <p>Marco 2 elementos 2 elements frame Plaque 2 éléments 181,5x91x12 mm</p>	39	822	Ver acabados See finishes Voir finitions	ref. 2 	1 Unidad Unit Unité
 <p>Marco 3 elementos 3 elements frame Plaque 3 éléments 253x91x12 mm</p>	39	823	Ver acabados See finishes Voir finitions	ref. 2 	1 Unidad Unit Unité
 <p>Marco 4 elementos 4 elements frame Plaque 4 éléments 324x91x12 mm</p>	39	824	Ver acabados See finishes Voir finitions	ref. 2 	1 Unidad Unit Unité

ACABADO FINISH FINITION



50.  
Dorado  
Golden  
Doré



53.  
Patiné americano  
Antique bronze  
Bronze ancien



51.  
Níquel satinado  
Satin nickel-plated  
Niquel satiné

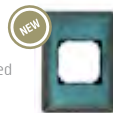

62.  
Patiné cobre  
Patinated cooper  
Patiné cuivre



46.  
Cobre antiguo  
Antique cooper  
Cuivre ancien



49.  
Antracita  
Anthracite  
Anthracite





www.tesli.com

www.tesli.com

www.tesli.com

Interiorismo: Carmen Barasona  
Interior Design: Carmen Barasona  
Architecture d'intérieur: Carmen Barasona



# Collection Garby Colonial



Interiorismo: Carmen Barasona  
Interior Design: Carmen Barasona  
Architecture d'intérieur: Carmen Barasona

Instalación empotrada.  
Mecanismos de 10AX - 250V~  
Bases de enchufe de 16A -250V~  
Contactos de plata de alto poder de ruptura.  
Construida con porcelana y termoplásticos técnicos.  
Marcos de madera y porcelana, posibilidades de personalización con marcos en crudo.  
Marcos para instalar en posición vertical u horizontal.

Fitting installation.  
10AX - 250V~ mechanisms.  
10/16A - 250V~ earthing sockets.  
Silver contacts with high breaking power.  
Manufactured with porcelain and technical thermoplastic materials.  
Wood and porcelain frames, possible custom-made finishes with natural wood frames.  
Frames for vertical or horizontal installations, fitted in universal boxes.

Installation encastrée.  
Mécanismes de 10A - 250V~  
Prises de courant 10/16A - 250V ~  
Contacts d'argent avec haut pouvoir de rupture.  
Fabriqués en porcelaine et à partir de thermoplastiques techniques.  
Plaques en bois et porcelaine, possibilités de personnalisation avec les plaques en bois cru.  
Plaques pour installations verticales ou horizontales.

# Garby Colonial Collection



**Lazo porcelana blanca - marco madera envejecida**  
White porcelain knob - old wood frame  
*Bouton porcelaine blanche - plaque bois vieilli*



**Lazo madera miel - marco miel**  
Honey wood knob - honey wood frame  
*Bouton bois miel - plaque bois miel*



**Lazo madera envejecida - marco madera envejecida**  
Old wood knob - old wood frame  
*Bouton bois vieilli - plaque bois vieilli*



**Lazo porcelana blanca - marco gris dorado**  
White porcelain knob, grey - gold wood frame  
*Bouton porcelaine blanche - plaque bois gris doré*



**Lazo retro porcelana blanca - marco blanco azul**  
White porcelain retro knob, white - blue wood frame  
*Bouton rétro porcelaine blanche - plaque bois blanc bleu*



**Lazo porcelana blanca - marco verde dorado**  
White porcelain knob, green - gold wood frame  
*Bouton porcelaine blanche - plaque bois vert doré*



**Lazo porcelana blanca - marco porcelana craquele**  
White porcelain knob - crackle porcelain frame  
*Bouton porcelaine blanche - plaque porcelaine craquelée*



**Lazo porcelana blanca - marco porcelana decor**  
White porcelain knob - decor porcelain frame  
*Bouton porcelaine blanche - plaque porcelaine décorée*



**Lazo retro porcelana blanca - marco porcelana blanca**  
White porcelain retro knob - white porcelain frame  
*Bouton rétro porcelaine blanche - plaque porcelaine blanche*



**Lazo porcelana negra - marco porcelana negra**  
Black porcelain knob - black porcelain frame  
*Bouton porcelaine noire - plaque porcelaine noire*















**Lazo retro porcelana negra - marco porcelana negra**  
Black retro porcelain knob - black porcelain frame  
*Bouton rétro porcelaine noire - plaque porcelaine noire*

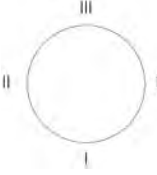

**Lazo madera envejecida - marco porcelana negra**  
Old wood knob - black porcelain frame  
*Bouton bois vieilli - plaque porcelaine noire*



	Serie Set Série	Código Code Cod	Acabado Finish Finition	Embalaje Packaging Emballage	
	31	306	Ver acabados See finishes Voir finitions	ref. 2 	<p>1 Unidad Unit Unité</p>
	31	308		ref. 2 	
	31	304		ref. 2 	
	31	314		ref. 2 	
	31	300	Ver acabados See finishes Voir finitions	ref. 2 	 <p>                     0 Circuitos cerrados                      I Circuito A abierto                      II Circuito A y B abierto                      III Circuito A cerrado y B abierto                      0 Both circuits Off                      I A circuit On                      II Both circuits On                      III B circuit On, A Off                      0 Circuits fermés                      I Circuit A ouvert                      II Circuits A et B ouverts                      III Circuit B ouvert, A fermé                 </p> <p>1 Unidad Unit Unité</p>
	31	302			
	<p>La posición 0 varía según la posición del otro conmutador                      0 position depends on the position of the other two-way switch                      La position 0 varie selon la position de l'autre va-et-vient</p>				
	31	310	17 27	ref. 2 	<p>1 Unidad Unit Unité</p>
	31	316		ref. 2 	
	31	343	25 Tuercas niqueladas Nickel-plated nuts Écrous niquelés	ref. 2 	<p>1 Unidad Unit Unité</p>

ACABADO FINISH FINITION



17.  
Porcelana blanca  
White porcelain  
Porcelaine blanche



18.  
Porcelana blanca/Madera miel  
White porcelain/Honey wood  
Porcelaine blanche/Bois miel



27.  
Porcelana negra  
Black porcelain  
Porcelaine noire















28.  
Porcelana retro negra  
Black retro porcelain  
Porcelaine rétro noire



29.  
Porcelana negra/Madera envejecida  
Black porcelain/Old wood  
Porcelaine noire/Bois vieilli

















		Serie Set Série	Código Code Cod	Acabado Finish Finition	Embalaje Packaging Emballage	
	Mecanismo para persiana 10A - 250V~ (para motores de 1,66A) Electric blinds mechanism 10A - 250V~ (for 1.66A motors) Mécanisme pour volets roulants 10A-250V~ (Pour moteurs 1,66A)	31	342	Ver acabados See finishes Voir finitions	ref. 2 	1 Unidad Unit Unité
	Mecanismo para tarjetas con indicador luminoso Card switch with luminous indicator Mécanisme pour cartes avec indicateur lumineux	37	935	05 Blanco White Blanc	ref. 2 	Se recomienda la instalación con relés Installation with relays is recommended L'installation avec relais est recommandée
		37	936		ref. 2 	
	Baliza luminosa 230V~ blanco-verde-rojo Luminous marker 230V~ white - green - red Balise lumineuse 230V~ blanche - verte - rouge	35	755	05 Blanco White Blanc	ref. 2 	1 Unidad Unit Unité
	Baliza luminosa 12/24V DC blanco-verde-rojo Luminous marker 12/24V DC white - green - red Balise lumineuse 12/24V DC blanche - verte - rouge	35	756		ref. 2 	
	Baliza de emergencia 230V~ Emergency marker 230V~ Balise d'urgence 230V~	35	760		ref. 2 	
	Base de enchufe 16A - 250V~ en plástico con obturador de seguridad Plastic two-pole socket outlet without earth 16A - 250V~ with shutters Prise de courant en plastique 16A - 250V~ avec obturateurs de sécurité	31	209	05 Blanco White Blanc	ref. 2 	Sólo reposición Only for replacement Uniquement pour remplacement
	Base de enchufe 16A - 250V~ en porcelana con obturador de seguridad Porcelain two-pole socket outlet without earth 16A - 250V~ with shutters Prise de courant en porcelaine 16A - 250V~ avec obturateurs de sécurité	31	209	02 Negro Black Noir 17 Porcelana blanca White porcelain Porcelaine blanche 27 Porcelana negra Black porcelain Porcelaine noire		
	Base de enchufe TT lateral en plástico 16A - 250V~ con obturador de seguridad Plastic two-pole socket with earth 16A - 250V~ with shutters Prise de courant en plastique 16A - 250V~ avec contact de terre schuko et obturateurs de sécurité	31	212	05 Blanco White Blanc 02 Negro Black Noir	ref. 2 	1 Unidad Unit Unité
	Base de enchufe TT lateral en porcelana 16A - 250V~ con obturador de seguridad Porcelain two-pole socket with earth 16A - 250V~ with shutters Prise de courant en porcelaine 16A - 250V~ avec contact de terre schuko et obturateurs de sécurité	31	212	17 Porcelana blanca White porcelain Porcelaine blanche 27 Porcelana negra Black porcelain Porcelaine noire		



21.  
Porcelana blanca/Madera envejecida  
White porcelain/Old wood  
Porcelaine blanche/Bois vieilli



23.  
Porcelana retro blanca  
White retro porcelain  
Porcelaine rétro blanche

		Serie Set Série	Código Code Cod	Acabado Finish Finition	Embalaje Packaging Emballage	
	<p>Base de enchufe TT sistema francés en plástico 16A -250V~ con obturador de seguridad Plastic french two-pole socket with earth pin 16A - 250V~ with shutters Prise de courant en plastique 16A-250V~ avec terre française et obturateurs de sécurité</p>	31	208	05 Blanco White Blanc	ref. 2 	1 Unidad Unit Unité
	<p>Base de enchufe TT sistema francés en porcelana 16A -250V~ con obturador de seguridad Porcelain french two-pole socket with earth pin 16A - 250V~ with shutters Prise de courant en porcelaine 16A-250V~ avec terre française et obturateurs de sécurité</p>	31	208	02 Negro Black Noir 17 Porcelana blanca White porcelain Porcelaine blanche 27 Porcelana negra Black porcelain Porcelaine noire		
	<p>Doble toma telefonía 6 vías 6 ways double telephone socket Double prise téléphone 6 voies</p>	31	706	17 27	ref. 2  ref. 2 	1 Unidad Unit Unité
	<p>Doble toma RJ45 CAT 6 Double 6 RJ45 CAT socket Double prise RJ45 CAT6</p>	31	707	17 27	ref. 2 	1 Unidad Unit Unité
	<p>Conjunto Teléfono 6 vías + RJ45 CAT6 6 ways telephone + 6 RJ45 CAT socket Double prise téléphone 6 voies + RJ45 CAT 6</p>	31	708		ref. 2  ref. 2 	
	<p>Tomas R/TV señal SAT ecualizadas R/TV and SAT sockets outlets Prises signal RTV et SAT</p>	35	712	05	ref. 2 	<p>Ver información técnica en página 107. See technical information at page 107. Voir information technique à la page 107.</p>
	<p>Toma única Single socket Prise unique</p>	35	713		ref. 2 	
	<p>Intermedia A Intermediate A Intermède A</p>	35	714		ref. 2 	
	<p>Toma final Final socket Prise finale</p>	35	711		ref. 2 	
	<p>Sólo tapa Only cover Seulement couvercle</p>	35	715		ref. 2 	



17.  
Porcelana blanca  
White porcelain  
Porcelaine blanche



18.  
Porcelana blanca/Madera miel  
White porcelain/Honey wood  
Porcelaine blanche/Bois miel









27.  
Porcelana negra  
Black porcelain  
Porcelaine noire



28.  
Porcelana retro negra  
Black retro porcelain  
Porcelaine rétro noire



29.  
Porcelana negra/Madera envejecida  
Black porcelain/Old wood  
Porcelaine noire/Bois vieilli









		Serie Set Série	Código Code Cod	Acabado Finish Finition	Embalaje Packaging Emballage	
	Regulador conmutador potencia 40-500W (incandescencia y halógenas) Dimmer two-way switch power 40-500W (for incandescence and halogen bulbs) Variateur - va-et-vient Puissance 40-500W (incandescent et halogène)	31	332	17 Porcelana blanca White porcelain Porcelaine blanche 27 Porcelana negra Black porcelain Porcelaine noire	ref. 2 	
						1 Unidad Unit Unité
	Regulador para motores 6A - 250V~ Dimmer for motors 6A-250V~ Variateur pour moteurs 6A-250V~	31	331	17 27	ref. 2 	
						1 Unidad Unit Unité
	Termostato para calefacción suelo radiante. Incluye sonda. Floor heating thermostat with sensor cable. Thermostat pour chauffage sol radiant, avec sonde	37	721	05 Blanco White Blanc	ref. 2 	Instalar solamente en marco especial para elementos cuadrados ref. 31-821.. Install only on special frame for square elements ref. 31-821.. À installer seulement sur plaque spéciale pour éléments carrés réf. 31-821..
	Termostato para calefacción temperatura ambiente Room temperature thermostat Thermostat chauffage température ambiante	37	722		ref. 2 	
						1 Unidad Unit Unité
	Detector de presencia 180º y Sonido Presence and sound detector 180º Détecteur de présence et son 180º	37	750	05	ref. 2 	Instalar solamente en marco especial para elementos cuadrados ref. 31-821.. Install only on special frame for square elements ref. 31-821.. À installer seulement sur plaque spéciale pour éléments carrés réf. 31-821..
						1 Unidad Unit Unité



21.  
Porcelana blanca/Madera envejecida  
White porcelain/Old wood  
Porcelaine blanche/Bois vieilli



23.  
Porcelana retro blanca  
White retro porcelain  
Porcelaine rétro blanche

		Serie Set Série	Código Code Cod	Acabado Finish Finition	Embalaje Packaging Emballage	
	Mecanismo interruptor con llave Switch mechanism with key Interrupteur à clés	31	906	05 Blanco White Blanc	ref. 2 	1 Unidad Unit Unité
	Carátula para salida de cables Cable outlet cover Cache pour sortie de câbles	31	927	17 Porcelana blanca White porcelain Porcelaine blanche 27 Porcelana negra Black porcelain Porcelaine noire	ref. 2 	1 Unidad Unit Unité
	Placa ciega Blind cover Cache neutre	31	656	17 27	ref. 2 	1 Unidad Unit Unité
	Potenciometro regulador de volumen Potentiometer for volume regulation Potentiomètre pour réglage du volume	31	924	17 27	ref. 2 	Ver notas técnicas en pág. 110. See technical notes at page 110. Voir l'information technique à la page 110.
						1 Unidad Unit Unité





		Serie Set Série	Código Code Cod	Acabado Finish Finition	Embalaje Packaging Emballage	
	Sintonizador de radio y control de volumen Radio tuner and volume regulator Radio tuner et réglage du volume	31	925	17 Porcelana blanca White porcelain Porcelaine blanche 27 Porcelana negra Black porcelain Porcelaine noire	ref. 2 	Ver notas técnicas en pág. 110. See technical notes at page 110. Voir l'information technique à la page 110.
	Altavoz para caja universal Potencia 2W Impedancia 16 Ω Loudspeaker for universal box Power 2W Impedance 16 Ω Hautparleur pour boîtier standard Puissance 2W - impédance 16Ω	31	926	05 Blanco White Blanc 02 Negro Black Noir	ref. 2 	Ver notas técnicas en pág. 110. See technical notes at page 110. Voir l'information technique à la page 110.
	Toma para altavoz Loudspeaker socket Prise pour hautparleur	31	905	05 02	ref. 2 	
	Zumbador 220V 80 dB intermitente Buzzer 220V 80dB intermittent Sonette 220V 80dB intermittent	31	390	05 02	ref. 2 	

1 Unidad Unit Unité

1 Unidad Unit Unité

1 Unidad Unit Unité

1 Unidad Unit Unité



21.  
Porcelana blanca/Madera envejecida  
White porcelain/Old wood  
Porcelaine blanche/Bois vieilli













23.  
Porcelana retro blanca  
White retro porcelain  
Porcelaine rétro blanche









05.  
Blanco  
White  
Blanc

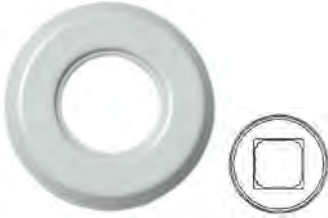

02.  
Negro  
Black  
Noir

		Serie Set Série	Código Code Cod	Acabado Finish Finition	Embalaje Packaging Emballage	
 	<p>Marco 1 elemento madera de haya 1 element beech wood frame Plaque 1 élément bois hêtre ø100x12 mm</p>	31	801	Ver acabados See finishes Voir finitions	ref. 2 	
	<p>Marco especial para 1 elemento cuadrado (a usar con refs 37 721.., 37 722.., 37 750..) Special frame for 1 square element (use with refs 37 721.., 37 722.., 37 750..) Plaque spéciale pour 1 élément carré (utiliser avec refs 37 721.., 37 722.., 37 750..)</p>	31	821		ref. 2 	
	<p>Marco 2 elementos madera de haya 2 elements beech wood frame Plaque 2 éléments bois hêtre 175x100x12 mm</p>	31	802	Ver acabados See finishes Voir finitions	ref. 2 	1 Unidad Unit Unité
	<p>Marco 3 elementos madera de haya 3 elements beech wood frame Plaque 3 éléments bois hêtre 246x100x12 mm</p>	31	803	Ver acabados See finishes Voir finitions	ref. 2 	1 Unidad Unit Unité
	<p>Marco 4 elementos madera de haya 4 elements beech wood frame Plaque 4 éléments bois hêtre 318x100x12 mm</p>	31	804	Ver acabados See finishes Voir finitions	ref. 2 	<p>Posibilidad de personalización de los marcos en acabado crudo Possible custom-made finishes with natural wood frames Possibilité de personnaliser les plaques en bois naturel</p>
						1 Unidad Unit Unité



		Serie Set Série	Código Code Cod	Acabado Finish Finition	Embalaje Packaging Emballage	
	<p>Marco 1 elemento porcelana 1 element porcelain frame Plaque 1 élément en porcelaine ø100x12 mm</p>	31	801	Ver acabados See finishes Voir finitions	ref. 2 	<p>1 Unidad Unit Unité</p>
	<p>Marco especial para 1 elemento cuadrado (a usar con refs 37 721.., 37 722.., 37 750..) Special frame for 1 square element (use with refs 37 721.., 37 722.., 37 750..) Plaque spéciale pour 1 élément carré (utiliser avec refs 37 721.., 37 722.., 37 750..)</p>	31	821		ref. 2 	
	<p>Marco 2 elementos porcelana 2 elements porcelain frame Plaque 2 éléments en porcelaine 175x100x12 mm</p>	31	802	Ver acabados See finishes Voir finitions	ref. 2 	<p>1 Unidad Unit Unité</p>
	<p>Marco 3 elementos porcelana 3 elements porcelain frame Plaque 3 éléments en porcelaine 246x100x12 mm</p>	31	803	Ver acabados See finishes Voir finitions	ref. 2 	<p>1 Unidad Unit Unité</p>







www.tesli.com

www.tesli.com

Interiorismo: Carmen Barasona - Fotografia: Jordi Canosa  
Interior Design: Carmen Barasona - Photography: Jordi Canosa  
Architecture d'intérieur: Carmen Barasona - Photographie: Jordi Canosa



# Garby Collection



**Interiorismo: Carmen Barasona – Fotografía: Jordi Canosa**  
Interior Design: Carmen Barasona – Photography: Jordi Canosa  
Architecture d'intérieur: Carmen Barasona – Photographie: Jordi Canosa

**Instalación de superficie.**  
**Mecanismos de 10AX – 250V~**  
**Bases de enchufe de 16A -250V~**  
**Contactos de plata de alto poder de ruptura.**  
**Construida con porcelana y termoplásticos técnicos.**  
**Marcos de madera y porcelana, posibilidades de personalización con marcos en crudo.**  
**Marcos para instalar en posición vertical u horizontal.**  
**Marcos para instalación en superficie y para instalación en caja universal con tornillos mediante adaptador especial.**

Surface installation.  
10AX - 250V~ mechanisms.  
10/16A - 250V~ earthing sockets.  
Silver contacts with high breaking power.  
Manufactured with porcelain and technical thermoplastic materials.  
Wood and porcelain frames, possible custom-made finishes with natural wood frames.  
Frames for vertical or horizontal installations, fitted in universal boxes.  
Frames for surface installation and fitting in standard box installation with screws and special adaptor.

*Installation en saillie.*  
*Mécanismes de 10A – 250V~*  
*Prises de courant 10/16A – 250V ~*  
*Contactos d'argent avec haut pouvoir de rupture.*  
*Fabriqués en porcelaine et à partir de thermoplastiques techniques.*  
*Plaques en bois et porcelaine, possibilités de personnalisation avec les plaques en bois cru.*  
*Plaques pour installations verticales ou horizontales.*  
*Plaques pour installation en saillie et pour installation sur boîte d'encastrement universelle avec vis et adaptateur spécial.*

# Garby Collection



**Porcelana blanca - lazo porcelana blanca**  
 White porcelain - white porcelain knob  
*Porcelaine blanche - bouton porcelaine blanche*



**Porcelana decor azul - lazo porcelana blanca**  
 Blue decor porcelain - white porcelain knob  
*Porcelaine décor bleu - bouton porcelaine blanche*



**Porcelana decor marrón - lazo porcelana blanca**  
 Brown decor porcelain - white porcelain knob  
*Porcelaine décor marron - bouton porcelaine blanche*



**Porcelana blanca - lazo retro porcelana blanca**  
 White porcelain - white porcelain retro knob  
*Porcelaine blanche - bouton rétro porcelaine blanche*



**Porcelana decor marrón - lazo madera miel**  
 Brown decor porcelain - honey wood knob  
*Porcelaine décor marron - bouton bois miel*



**Porcelana blanca - lazo madera envejecida**  
 White porcelain - old wood knob  
*Porcelaine blanche - bouton bois vieilli*



**Porcelana decor azul - lazo madera envejecida**  
 Blue decor porcelain - old wood knob  
*Porcelaine décor bleu - bouton bois vieilli*



**Porcelana decor marrón - lazo madera envejecida**  
 Brown decor porcelain - old wood knob  
*Porcelaine décor marron - bouton bois vieilli*





**Porcelana decor azul – lazo retro porcelana blanca**  
 Blue decor porcelain – white porcelain retro knob  
*Porcelaine décor bleu – bouton rétro porcelaine blanche*



**Porcelana decor marrón – lazo retro porcelana blanca**  
 Brown decor porcelain – white porcelain retro knob  
*Porcelaine décor marron – bouton rétro porcelaine blanche*



**Porcelana blanca – lazo madera miel**  
 White porcelain – honey wood knob  
*Porcelaine blanche – bouton bois miel*



**Porcelana decor azul – lazo madera miel**  
 Blue decor porcelain – honey wood knob  
*Porcelaine décor bleu – bouton bois miel*



**Porcelana reggia – lazo patiné americano**  
 Reggia porcelain – antique bronze knob  
*Porcelaine reggia – bouton bronze ancien*



**Porcelana negra – lazo porcelana negra**  
 Black porcelain – black porcelain knob  
*Porcelaine noire – bouton porcelaine noire*



**Porcelana negra – lazo retro porcelana negra**  
 Black porcelain – black porcelain retro knob  
*Porcelaine noire – bouton rétro porcelaine noire*



**Porcelana negra – lazo madera envejecida**  
 Black porcelain – old wood knob  
*Porcelaine noire – bouton bois vieilli*

	Serie Set Série	Código Code Cod	Acabado Finish Finition	Embalaje Packaging Emballage	
	Interrupitor 10AX - 250V~ Switch 10AX - 250V~ Interrupteur unipolaire 10AX-250V~	30	306	Ver acabados See finishes Voir finitions	ref. 2 
	Conmutador 10AX - 250V~ Two-way switch 10AX - 250V~ Va-et-vient 10AX-250V~	30	308		ref. 2 
	Cruzamiento 10AX- 250V~ Crossing switch 10AX - 250V~ Permutateur 10AX-250V~	30	304		ref. 2 
	Interrupitor bipolar 10AX - 250V~ Two-pole switch 10AX - 250V~ Interrupteur bipolaire 10AX-250V~	30	314		ref. 2 
	Mecanismo para persianas 10A - 250V~ Electric blinds mechanism 10A - 250V~ Mécanisme pour volets roulants 10A-250V~	30	342	Ver acabados See finishes Voir finitions	ref. 2 
	Base normal superficie 16A - 250V~ Two-pole socket outlet without earth 10/16A - 250V~ Prise de courant 10/16A - 250V~ avec obturateurs de sécurité	30	209	17 11 13 15 27	ref. 2 
	Base superficie en porcelana 16A - 250V~ con obturadores de seguridad Porcelain two-pole socket 16A - 250V~ with shutters Prise de courant en porcelaine 16A - 250V~ avec obturateurs de sécurité	30	205		
	Base superficie TT 16A - 250V~ con obturadores de seguridad German two-pole socket With shutters With earth 10/16A - 250V~ Prise de courant avec terre allemande 10/16A - 250V~ avec obturateurs de sécurité	30	204	17 11 13 15 27	ref. 2 

1 Unidad Unit Unité

1 Unidad Unit Unité

Sólo reposición  
Only for replacement  
Uniquement pour remplacement

1 Unidad Unit Unité

1 Unidad Unit Unité

ACABADO FINISH FINITION



17.



11.



13.



30.



31.



32.









18.







12.



		Serie Set Série	Código Code Cod	Acabado Finish Finition	Embalaje Packaging Emballage	
	Base superficie TT 16A- 250V~ sistema francés con obturador French two-pole socket With earth pin 10/16A - 250V~ With shutters Prise de courant 16A-250V~ avec terre française et obturateurs de sécurité	30	208	17 11 13 15 27	ref. 2 	1 Unidad Unit Unité
	Base superficie T.T.16A.-250V~. Cuerpo e interior de porcelana. German two-pole socket with earth 10/16A.-250V~. Porcelain case. Prise de courant avec terre allemande 10/16A.-250V~. Corps et intérieur de porcelaine.	30	202	17 11 13 15 27	ref. 2 	1 Unidad Unit Unité
	Pulsador timbre 10a 250v~ 24v dc sin paso de cable Pushbutton 10a 250v~ 24v dc sin paso de cable Bouton poussoir 10a 250v~ 24v dc sin paso de cable	30	310	17 11 13 15 27	ref. 2 	1 Unidad Unit Unité
	Doble pulsador 10A - 250V~ 24V DC Double pushbutton 10A - 250V~ 24V DC Double bouton poussoir 10A-250V~ - 24V DC	30	343	17 11 13 15	ref. 2 	1 Unidad Unit Unité



			Serie Set Série	Código Code Cod	Acabado Finish Finition	Embalaje Packaging Emballage	
	Tomas señal RTV/SAT ecualizadas RTV/SAT sockets outlets Prises signal RTV et SAT	Toma única Single socket Prise unique	30	712	11 13 15	ref. 2 	Ver información técnica en página 107. See technical information at page 107. Voir information technique à la page 107.
		Intermedia A Intermediate A Intermède A	30	713	17 27		
		Intermedia B Intermediate B Intermède B	30	714			
		Toma final Final socket Prise finale	30	709			
1 Unidad Unit Unité							
	Doble toma telefonía 6 vías 6 ways double telephone socket Double prise téléphone 6 voies		30	706	11 13 15 17 27	ref. 2 	
1 Unidad Unit Unité							
	Doble toma RJ45 Double RJ45 socket Double prise RJ45		30	707	11 13 15 17 27	ref. 2 	
	Conjunto Teléfono 6 vías + RJ45 CAT6 6 ways double Telephone + 6 RJ45 CAT socket Double prise téléphone 6 voies + RJ45 CAT6		30	708			
1 Unidad Unit Unité							
	Tapa ciega Blind cover Couvercle neutre		30	656	11 13 15 17 27	ref. 2 	
1 Unidad Unit Unité							

ACABADO FINISH FINITION



17.



11.



13.



15.



27.

		Serie Set Série	Código Code Cod	Acabado Finish Finition	Embalaje Packaging Emballage	
	Salida de cables Cable outlet cover Sortie de câbles	30	927	11 13 15 17 27	ref. 2 	1 Unidad Unit Unité
	Florón para lámpara medida ø100x34 mm Lamps médaillon size ø100x34 mm Rosette pour luminaires mesure: ø100x34mm	30	940	17	ref. 2 	1 Unidad Unit Unité
	Bastidor con garras para caja universal sin tornillos Claws support for universal box without screws Châssis métallique pour boîte sans vis	20	901	97 Metal Metallic Métal	ref. 0 	Sólo para peanas ref. 30.80x... Only for wood bases ref. 30.80x... Seulement pour socles réf. 30.80x...  ref. 0 - 25 Unidades Units Unités
	Los conductores PVC con recubrimiento trenzado se encuentran dentro de la sección "sistemas decorativos de instalación en superficie" pag. 76 Find intertwined PVC wire on the section "surface installation decorative systems" page.76 Les conducteurs PVC avec recouvrement torsadé se trouvent dans la partie « Systèmes décoratifs d'installation en saillie », page 76					

		Serie Set Série	Código Code Cod	Acabado Finish Finition	Embalaje Packaging Emballage	
	<p>Peana de madera de haya superficie para 1 elemento ø100x12 mm Beech wood base 1 element surface mounting ø100x11,75 mm Socle en bois hêtre pour 1 élément saillie ø100x12 mm</p>	30	811	00 19 21	ref. 2 	<p>Incluye tornillos para montaje mecanismo-peana Screws included for fixing mechanism on wood plate Inclues vis de montage mécanisme-socle</p>
	<p>Peana de madera de haya superficie para 2 elementos 175x100x12 mm Beech wood base 2 elements surface mounting 175x100x11,75 mm Socle en bois hêtre pour 2 éléments saillie 175x100x12 mm</p>	30	812	00 19 21	ref. 2 	<p>Incluye tornillos para montaje mecanismo-peana Screws included for fixing mechanism on wood plate Inclues vis de montage mécanisme-socle</p>
	<p>Peana de madera de haya superficie para 3 elementos 246,5x100x12 mm Beech wood base 3 elements surface mounting 246.5x100x12 mm Socle en bois hêtre pour 3 éléments saillie 246,5x100x12 mm</p>	30	813	00 19 21	ref. 2 	<p>Incluye tornillos para montaje mecanismo-peana Screws included for fixing mechanism on wood plate Inclues vis de montage mécanisme-socle</p>
	<p>Peana de madera de haya para 1 elemento ø95x22 mm para instalación con caja universal o superficie Beech wood base 1 element ø95x22 mm for universal box or surface installations Socle en bois hêtre pour 1 élément ø95x22 mm Pour installations sur boîte standard ou saillie</p>	30	801	00 19 21	ref. 2 	<p>Incluye tornillos para montaje mecanismo-peana y peana-caja de empotrar Screws included for fixing mechanism-wood base and wood base on fitting box Inclues vis de montage mécanisme-socle et socle-boîte d'encastrement</p> <p>Posibilidad de personalización de los marcos en acabado crudo Possible custom-made finishes with natural wood frames Possibilité de personnaliser les plaques en bois naturel</p>

1 Unidad Unit Unité

1 Unidad Unit Unité

1 Unidad Unit Unité

1 Unidad Unit Unité

ACABADO FINISH FINITION



00.  
Crudo  
Natural  
Cru



19.  
Miel  
Honey  
Miel



21.  
Envejecida  
Old wood  
Bois vieilli



	Serie Set Série	Código Code Cod	Acabado Finish Finition	Embalaje Packaging Emballage	
 <p>Peana de madera de haya para 2 elementos 181x95,5x22 mm para instalación con caja universal o tubo Beech wood base 2 elements 181x95.5x22 mm for universal box or tube installations Socle en bois hêtre pour 2 éléments 181x95,5x22 mm Pour installations sur boîte standard ou saillie</p>	30	802	00 19 21	ref. 2 	Incluye tornillos para montaje mecanismo-peana y peana-caja de empotrar Screws included for fixing mechanism-wood plate and wood plate on fitting box Inclues vis de montage mécanisme-socle et socle-boîte d'encastrement
 <p>Peana de madera de haya para 3 elementos 252,5x95,5x22 mm para instalación con caja universal o tubo Beech wood base 3 elements 252.5x95.5x22 mm for universal box or tube installations Socle en bois hêtre pour 3 éléments 252,5x95,5x22 mm Pour installations sur boîte standard ou saillie</p>	30	803	00 19 21	ref. 2 	Incluye tornillos para montaje mecanismo-peana y peana-caja de empotrar Screws included for fixing mechanism-wood plate and wood plate on fitting box Inclues vis de montage mécanisme-socle et socle-boîte d'encastrement
 <p>Adaptador para marcos en superficie apto para: Garby Colonial, Venezia Clasica, Venezia Toscana, Venezia Metal y Venezia Carré. Adaptor for frames in surface installations suitable for: Garby Colonial, Venezia Clasica, Venezia Toscana, Venezia Metal and Venezia Carré. Adaptateur pour cadres - installation: saillie Valable pour: Garby Colonial, Venezia Clásica, Venezia Toscana, Venezia Métal et Venezia Carré.</p>	30	950	98	ref. 2 	
 <p>Adaptador para marcos en superficie apto para: Garby Colonial, Venezia Clasica, Venezia Toscana, Venezia Metal y Venezia Carré. Adaptor for frames in surface installations suitable for: Garby Colonial, Venezia Clasica, Venezia Toscana, Venezia Metal and Venezia Carré. Adaptateur pour cadres - installation saillie Valable pour: Garby Colonial, Venezia Clásica, Venezia Toscana, Venezia Métal et Venezia Carré.</p>	30	951	98	ref. 2 	Ver esquemas de instalación en la página 100. See installation instructions at page 100. Voir les schémas de montage à la page 100.

1 Unidad Unit Unité

1 Unidad Unit Unité

6 Unidades Units Unités

6 Unidades Units Unités



www.tesli.com

www.tesli.com

www.tesli.com

Interiorismo: Salvador Fresneda – Fotografia: Jordi Canosa  
Interior Design: Salvador Fresneda – Photography: Jordi Canosa  
Architecture d'intérieur: Salvador Fresneda – Photographie: Jordi Canosa

# Dimbler Collection



Interiorismo: Salvador Fresneda – Fotografía: Jordi Canosa  
Interior Design: Salvador Fresneda – Photography: Jordi Canosa  
Architecture d'intérieur: Salvador Fresneda – Photographie: Jordi Canosa

Instalación de superficie o empotrada.  
Mecanismos de 10AX - 250V~  
Contactos de plata de alto poder de ruptura.  
Construida con porcelana y latón.  
Combinable con peanas Garby y marcos  
Garby Colonial y Venezia.

Fitting or surface installation.  
10AX - 250V~ mechanisms.  
Silver contacts with high breaking power.  
Made of porcelain and brass.  
Usable with Garby, Garby Colonial and Venezia frames.

*Installation en saillie ou encastrée.  
Mécanismes de 10A - 250V~  
Contacts d'argent avec haut pouvoir de rupture.  
Fabriqués en porcelaine et laiton.  
Compatible avec les plaques Garby, Garby Colonial  
et Venezia.*



# Dimbler Collection



**Porcelana blanca - manecilla dorada**  
White porcelain - golden key  
*Porcelaine blanche - manette dorée*



**Porcelana blanca - manecilla cromada**  
White porcelain, chrome-plated key  
*Porcelaine blanche - manette chromée*



**Porcelana blanca - manecilla patiné americano**  
White porcelain - antique bronze key  
*Porcelaine blanche - manette bronze ancien*



**Base porcelana blanca - latón dorado - manecilla dorada**  
White porcelain - golden brass case - golden key  
*Corps porcelaine blanche - laiton niquelé - manette dorée*



**Base porcelana blanca - latón níquel satinado - manecilla cromada**  
White porcelain, nickel-plated brass case - chrome-plated key  
*Corps porcelaine blanche - laiton niquel satiné - manette chromée*



**Base porcelana blanca - latón dorado - manecilla patiné americano**  
White porcelain - antique bronze case - antique bronze key  
*Corps porcelaine blanche - laiton bronze ancien - manette bronze ancien*





**Mecanismos compatibles con los marcos y accesorios de las Colecciones Garby y Garby Colonial y con los marcos de la Colección Venezia.**

Combinable mechanisms with frames and accessories of Garby and Garby Colonial Collections and Venezia Collection frames.

*Mécanismes compatibles avec les plaques et accessoires des Collections Garby et Garby Colonial et avec les plaques de la Collection Venezia.*

**Nuevo Dimbler porcelana + Nueva base de enchufe Garby porcelana + Peana Garby de madera envejecida para instalación en tubo**

New porcelain Dimbler + New porcelain Garby socket + Old wood Garby frame for tube installation

*Nouveau Dimbler porcelaine + Nouvelle prise Garby porcelaine + Plaque Garby bois vieilli pour installation avec tuyau*



**Dimbler porcelana patiné americano + Base de enchufe Garby Colonial + Marco Venezia Toscana**

Porcelain antique bronze Dimbler + Garby Colonial socket + Venezia Toscana frame

*Dimbler porcelaine bronze ancien + Prise Garby Colonial + Plaque Venezia Toscana*



**Dimbler porcelana dorado + Marco Venezia Carré**

Gold porcelain Dimbler + Venezia Carré frame

*Dimbler porcelaine doré + Plaque Venezia Carré*





[www.tesli.com](http://www.tesli.com)



[www.tesli.com](http://www.tesli.com)

[www.tesli.com](http://www.tesli.com)

Interiorismo: Hector Ruíz - Fotografía: Benjamín Alcázar  
Interior Design: Hector Ruíz - Photograph: Benjamín Alcázar  
Architecture d'intérieur: Hector Ruíz - Photograph: Benjamín Alcázar

Serie Set Série Código Code Cod Acabado Finish Finition Embalaje Packaging Emballage



Interruptor unipolar 10AX - 250V~  
One pole switch 10AX - 250V~  
Interrupteur unipolaire 10AX-250V~

60

306

Ver acabados  
See finishes  
Voir finitions

ref. 2 

Conmutador 10AX - 250V~  
Two-way switch 10AX - 250V~  
Va-et-vient 10AX-250V~

60

308

ref. 2 

Cruzamiento 10AX - 250V~  
Crossing switch 10AX - 250V~  
Permutateur 10AX-250V~

60

304

ref. 2 

Interruptor bipolar 10AX - 250V~  
Two-pole switch 10AX - 250V~  
Interrupteur bipolaire 10AX-250V~

60

314

ref. 2 

Pulsador Rocking 10A - 250V ~ 24V DC  
Rocking Pushbutton 10A - 250V~ 24V DC  
Bouton poussoir Rocking 10A-250V~ - 24V DC

60

312

ref. 2 

1 Unidad Unit Unité



Pulsador 10A -250 v ~ 24v DC  
Pushbutton 10A -250 v ~ 24v DC  
Bouton poussoir 10A -250 v ~ 24v DC

60

310

Ver acabados  
See finishes  
Voir finitions

ref. 2 

1 Unidad Unit Unité

ACABADO FINISH FINITION

Sin paso de cable  
Without cable inlet  
Sans pas de câble



55.  
Dorado  
Golden  
Doré



56.  
Níquel satinado  
Satin nickel-plated  
Níquel satiné



57.  
Patiné americano  
Antique bronze  
Bronze ancien



63.  
Dorado  
Golden  
Doré



64.  
Cromado  
Chrome  
Chromé



65.  
Patiné americano  
Antique bronze  
Bronze ancien

Con paso de cable  
With cable inlet  
Avec pas de câble



50.  
Dorado  
Golden  
Doré



51.  
Níquel satinado  
Satin nickel-plated  
Níquel satiné



53.  
Patiné americano  
Antique bronze  
Bronze ancien



43.  
Dorado  
Golden  
Doré



44.  
Cromado  
Chrome  
Chromé



45.  
Patiné americano  
Antique bronze  
Bronze ancien





www.tesli.com

www.tesli.com

www.tesli.com

**Interiorismo: Carmen Barasona - Fotografía: Benjamín Alcázar**  
Interior Design: Carmen Barasona - Photography: Benjamín Alcázar  
Architecture d'intérieur: Carmen Barasona - Photographie: Benjamín Alcázar



## Sistemas decorativos de instalación en superficie

Surface installation decorative systems

*Systèmes décoratifs d'installation en saillie*



www.tesli.com

www.tesli.com

www.tesli.com

Fontini presenta una amplia gama de sistemas de instalación en superficie para todo tipo de estilos decorativos. Desde la instalación con cable trenzado y aisladores para ambientes rústicos, hasta instalaciones con tubo y cajas metálicas para ambientes de estilo industrial tipo loft.

Fontini launches a wide range of surface installation systems for any decorative style. From intertwined cable and insulators installations for country atmospheres, up to metallic tubes and boxes for industrial loft atmospheres.

*Fontini vous présente sa nouvelle gamme de systèmes d'installation en saillie pour tout type de styles décoratifs. De l'installation avec câble torsadé et isolateurs pour des atmosphères plutôt rustiques, aux installations avec tuyau et boîtes métalliques pour des ambiances plus industrielles type loft.*

Interiorismo: Antioquia / Belén Lopez – Fotografía: Benjamín Alcázar  
Interior Design: Antioquia / Belén Lopez – Photography: Benjamín Alcázar  
Architecture d'intérieur: Antioquia / Belén Lopez – Photographie: Benjamín Alcázar



			Serie Set Série	Código Code Cod	Acabado Finish Finition	Embalaje Packaging Emballage
Conductor PVC 750 V con recubrimiento de algodón trenzado Intertwined PVC wire 750 V with cotton coating Fil conducteur coton torsadé PVC 750V	2x1 mm	30	970	05 Blanco White Blanc	ref. 2	
	2x1,5 mm	30	976			
	2x2,5 mm	30	977			
	3x1 mm	30	978			
	3x1,5 mm	30	979			

Según Reglamento Electrotécnico para Baja Tensión (Real Decreto 842/2002) con entrada en vigor el 18 de Septiembre de 2003, el cable trenzado PVC de 750 V únicamente es apto para reformas o modificaciones de instalaciones existentes que no afecten a más del 50% de la potencia instalada.

Fontini recommends checking the electrical regulations of your country before installing intertwined cable. Fixed installations may not be allowed using the cable without an extra protection,

Fontini recommande vérifier la normative électrique de votre pays avant d'installer câble torsadé. Les installations fixes avec le câble peuvent ne être pas autorisées sans une protection extra.

Conductor PVC blindado con aislante mineral ignífugo 750 V trenzado Intertwined pvc wire 750 V with mineral fireproof coating Fil conducteur torsadé PVC 750V avec isolant minéral ignifugé	2x1,5 mm	30	971	05 Blanco White Blanc	ref. 2
	2x2,5 mm	30	972		
	3x1,5 mm	30	974		
	3x2,5 mm	30	975		
	4x1,5 mm	30	980*		

Rollos 50 m Rolls 50 m Rouleau 50 m  
\*980 Rollos 25 m \*980 Rolls 25 m Rouleau 25 m











Caja de empalmes de porcelana pequeña, para cable o tubo Ø 16,20 mm. Medida exterior Ø 72 mm (incluye tacos para pared y tornillos para montaje). Porcelain connection box for cable or tube Ø 16,20 mm. External size: Ø 72 mm (includes wall plugs and screws for assembly). Boîte de dérivation en porcelaine pour câble ou tuyau Ø 16,20 mm. Dimensions extérieures: Ø 72 mm (chevilles murales et vis pour le montage incluses).	30	399	17	ref. 2
---	----	-----	----	--------

1 Unidad Unit Unité



Caja de empalmes de porcelana para cable o tubo Ø 16,20 y 25 mm. Medida exterior Ø 116 x 56 mm (incluye tacos para pared y tornillos para montaje). Porcelain connection box for cable or tube Ø 16,20 and 25 mm. External size: Ø 116 x 56mm (includes wall plugs and screws for assembly). Boîte de dérivation en porcelaine pour câble ou tuyau Ø 16,20 et 25 mm. Dimensions extérieures: Ø 116 x 56 mm (chevilles murales et vis pour le montage incluses).	30	401	17	ref. 2
---	----	-----	----	--------

1 Unidad Unit Unité





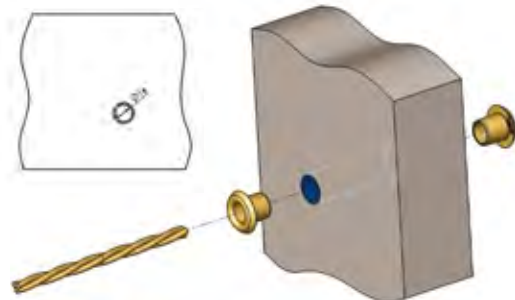

	Serie Set Série	Código Code Cod	Acabado Finish Finition	Embalaje Packaging Emballage	
	30	913	05	ref. 0  ref. 2 	
	30	913	17		ref. 0 - 25 Unidades Units Unités ref. 2 - 5 Unidades Units Unités
	30	913	03	ref. 0  ref. 2 	
	30	913	47		ref. 0 - 25 Unidades Units Unités ref. 2 - 5 Unidades Units Unités
	30	938	05 03	ref. 2 	2 Unidades Units Unités

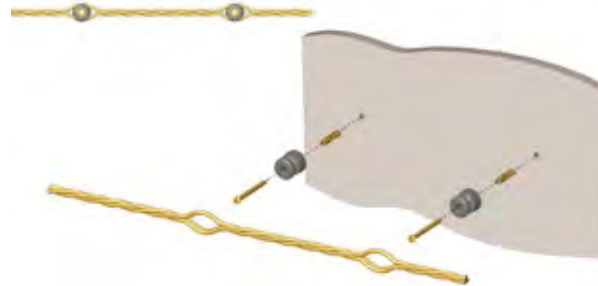
Aplicación del tapón pasamuros  
Use of the wall-passing cap  
Application du bouchon passe-murs











Instalación de cable trenzado con aisladores  
Installation of intertwined cable with insulators  
Installation de câble torsadé avec isolateurs



	Serie Set Série	Código Code Cod	Acabado Finish Finition	Embalaje Packaging Emballage	
	30	401	22	ref. 2 	<p>Incluye tornillos para montaje mecanismo-peana Screws included for fixing mechanism on wood base Inclues vis de montage mécanisme-socle</p> <p style="text-align: right;">1 Unidad Unit Unité</p>
	30	399	22	ref. 2 	<p>Incluye tornillos para montaje mecanismo-peana y peana-caja de empotrar Screws included for fixing mechanism-wood base and wood base on fitting box Inclues vis de montage mécanisme-socle et socle-boîte d'encastrement</p> <p style="text-align: right;">1 Unidad Unit Unité</p>
	30	402	22	ref. 2 	<p style="text-align: right;">1 Unidad Unit Unité</p>



	Serie Set Série	Código Code Cod	Acabado Finish Finition	Embalaje Packaging Emballage	
	<p>Tubo metálico para instalación en superficie Ø16mm Metallic tube with for surface installation Ø16mm Tuyau métallique pour installation saillie Ø16mm</p>	30	016	22	<p>ref. 2 </p>
	<p>Tubo metálico para instalación en superficie Ø20mm Metallic tube with for surface installation Ø20mm Tuyau métallique pour installation saillie Ø20mm</p>	30	020	22	
	<p>Tubo metálico para instalación en superficie Ø25mm Metallic tube with for surface installation Ø25mm Tuyau métallique pour installation saillie Ø25mm</p>	30	025	22	
	<p>Grapa para fijación tubo Ø16mm (incluye tacos para pared y tornillos para montaje) Fixing clip for Ø20mm tubes (includes wall plugs and screws for assembly) Crampon pour fixation de tuyau Ø16mm (inclue chevilles murales et vis pour le montage)</p>	30	716	03	<p>ref. 2 </p>
	<p>Grapa para fijación tubo Ø20mm (incluye tacos para pared y tornillos para montaje) Fixing clip for Ø20mm tubes (includes wall plugs and screws for assembly) Crampon pour fixation de tuyau Ø20mm (inclue chevilles murales et vis pour le montage)</p>	30	720	03	
	<p>Grapa para fijación tubo Ø25mm (incluye tacos para pared y tornillos para montaje) Fixing clip for Ø25mm tubes (includes wall plugs and screws for assembly) Crampon pour fixation de tuyau Ø25mm (inclue chevilles murales et vis pour le montage)</p>	30	725	03	
	<p>Abrazadera para fijación tubo Ø16mm (incluye tacos para pared y tornillos para montaje) Fixing clamp for Ø16mm tubes (includes wall plugs and screws for assembly) Clamp pour fixation de tuyau Ø16mm (inclue chevilles murales et vis pour le montage)</p>	30	816	03	<p>ref. 2 </p>
	<p>Abrazadera para fijación tubo Ø20mm (incluye tacos para pared y tornillos para montaje) Fixing clamp for Ø20mm tubes (includes wall plugs and screws for assembly) Clamp pour fixation de tuyau Ø20mm (inclue chevilles murales et vis pour le montage)</p>	30	820	03	
	<p>Abrazadera para fijación tubo Ø25mm (incluye tacos para pared y tornillos para montaje) Fixing clamp for Ø25mm tubes (includes wall plugs and screws for assembly) Clamp pour fixation de tuyau Ø25mm (inclue chevilles murales et vis pour le montage)</p>	30	825	03	
	<p>Manguito para unión de tubos Ø16mm Coupling for Ø16mm tubes Manchon de jonction pour tuyau Ø16mm</p>	30	516	22	<p>ref. 2 </p>
	<p>Manguito para unión de tubos Ø20mm Coupling for Ø20mm tubes Manchon de jonction pour tuyau Ø20mm</p>	30	520	22	
	<p>Manguito para unión de tubos Ø25mm Coupling for Ø25mm tubes Manchon de jonction pour tuyau Ø25mm</p>	30	525	22	
					<p>Pack: 4 tubos x 3m (12m en total) Pack: 4 tubes x 3m (total 12mts) Pack: 4 tuyaux x 3m (12m en total)</p>
					<p>25 Unidades Units Unités</p>
					<p>25 Unidades Units Unités</p>
					<p>10 Unidades Units Unités 10 Unidades Units Unités 5 Unidades Units Unités</p>









ACABADO FINISH FINITION













22.  
Metal envejecido  
Aged metal  
Métal vieilli



03.  
Marrón  
Brown  
Marron

	Serie Set Série	Código Code Cod	Acabado Finish Finition	Embalaje Packaging Emballage	
	30	116	22	ref. 2 	1 Unidad Unit Unité
	30	120	22		
	30	125	22		
	30	416	22	ref. 2 	1 Unidad Unit Unité
	30	420	22		
	30	425	22		
	30	616	22	ref. 2 	1 Unidad Unit Unité
	30	620	22		
	30	625	22		
	60	952	03	ref. 2 	6 Unidades Units Unités



		Serie Set Série	Código Code Cod	Acabado Finish Finition	Embalaje Packaging Emballage	
	<p>Peana de madera de haya para instalación con tubo o cable trenzado para 1 elemento. Ø100 x 28 mm. Instalación horizontal o vertical (incluye tacos para pared y tornillos de montaje).</p> <p>Wood frame for tube or cable installation for 1 element. Ø100 x 28 mm. Horizontal or vertical installation (includes wall plugs and screws for assembly).</p> <p>Socle en bois pour installation saillie avec câble ou tuyau 1 élément. Ø100 x 28 mm. Installation verticale ou horizontale (chevilles murales et vis pour le montage incluses).</p>	30	821	00 19 21	ref. 2 	1 Unidad Unit Unité
	<p>Peana de madera de haya para instalación con tubo o cable trenzado para 2 elementos. Ø183 x 100 mm. Instalación vertical (incluye tacos para pared y tornillos de montaje).</p> <p>Wood frame for tube or cable installation for 2 elements. Ø183 x 100 mm. Vertical installation (includes wall plugs and screws for assembly).</p> <p>Socle en bois pour installation saillie avec câble ou tuyau 2 éléments. Ø183 x 100 mm. Installation verticale (chevilles murales et vis pour le montage incluses).</p>	30	822	00 19 21	ref. 2 	1 Unidad Unit Unité
	<p>Peana de madera de haya para instalación con tubo o cable trenzado para 2 elementos. Ø183 x 100 mm. Instalación horizontal (incluye tacos para pared y tornillos de montaje).</p> <p>Wood frame for tube or cable installation for 2 elements. Ø183 x 100 mm. Horizontal installation (includes wall plugs and screws for assembly).</p> <p>Socle en bois pour installation saillie avec câble ou tuyau 2 éléments. Ø183 x 100 mm. Installation horizontale (chevilles murales et vis pour le montage incluses).</p>	30	832	00 19 21	ref. 2 	1 Unidad Unit Unité
	<p>Peana de madera de haya para instalación con tubo o cable trenzado para 3 elementos. Ø255 x 100 mm. Instalación vertical (incluye tacos para pared y tornillos de montaje).</p> <p>Wood frame for tube or cable installation for 3 elements. Ø255 x 100 mm. Vertical installation (includes wall plugs and screws for assembly).</p> <p>Socle en bois pour installation saillie avec câble ou tuyau 3 éléments. Ø255 x 100 mm. Installation verticale (chevilles murales et vis pour le montage incluses).</p>	30	823	00 19 21	ref. 2 	1 Unidad Unit Unité
	<p>Peana de madera de haya para instalación con tubo o cable trenzado para 3 elementos. Ø255 x 100 mm. Instalación horizontal (incluye tacos para pared y tornillos de montaje).</p> <p>Wood frame for tube or cable installation for 3 elements. Ø255 x 100 mm. Horizontal installation (includes wall plugs and screws for assembly).</p> <p>Socle en bois pour installation saillie avec câble ou tuyau 3 éléments. Ø255 x 100 mm. Installation horizontale (chevilles murales et vis pour le montage incluses).</p>	30	833	00 19 21	ref. 2 	<p>Posibilidad de personalización de los marcos en acabado crudo</p> <p>Possible custom-made finishes with natural wood frames</p> <p>Possibilité de personnaliser les plaques en bois naturel</p>

ACABADO FINISH FINITION



00.  
Crudo  
Natural  
Cru



19.  
Miel  
Honey  
Miel



21.  
Envejecida  
Old wood  
Vieilli

1 Unidad Unit Unité



Adaptador para instalación tubo Ø20 mm en peana madera  
Adaptor for tube Ø20 mm installation in wood frame.  
Adaptateur pour installation de tuyau Ø20 mm en socle

Serie  
Set Série

30

Código  
Code Cod

007

Acabado  
Finish Finition

03

Embalaje  
Packaging Emballage

ref. 2 

Ver esquemas de instalación en la página 99.  
See installation instructions at page 99.  
Voir les schémas de montage à la page 99.

1 Unidades Units Unités



Spray reparador de pintura metal envejecido 200ml  
Aged metal paint repair spray 200ml  
Spray réparateur de peinture métal vieilli 200 ml

30

001

22

ref. 2 

1 Unidad Unit Unité





[www.tesli.com](http://www.tesli.com)

[www.tesli.com](http://www.tesli.com)

[www.tesli.com](http://www.tesli.com)

Interiorismo: Carmen Barasona - Fotografía: Benjamín Alcázar  
Interior Design: Carmen Barasona - Photography: Benjamín Alcázar  
Architecture d'intérieur: Carmen Barasona - Photographie: Benjamín Alcázar

Serie Set Série Código Code Cod Acabado Finish Finition Embalaje Packaging Emballage

NEW



Caja de superficie F-37 1 elemento 86x86x40mm  
F-37 1 element surface box 86x86x40mm  
Boîte saillie F-37 1 élément 86x86x40mm

37

401

51 Níquel satinado  
Satin nickel-plated  
Niquel satiné

ref. 2



1 Unidades Units Unités

NEW



Caja de superficie instalación vertical F-37 2 elementos  
86x160x40mm  
F-37 2 elements surface box for vertical installation  
86x160x40mm  
Boîte saillie installation verticale F-37 2 éléments  
86x160x40mm

37

402

51 Níquel satinado  
Satin nickel-plated  
Niquel satiné

ref. 2



Caja de superficie instalación horizontal F-37 2 elementos  
86x160x40mm  
F-37 2 elements surface box for horizontal installation  
86x160x40mm  
Boîte saillie pour installation horizontale F-37 2 éléments  
86x160x40mm

37

405

51 Níquel satinado  
Satin nickel-plated  
Niquel satiné

1 Unidad Unit Unité

NEW



Caja de superficie instalación vertical F-37 3 elementos  
86x230x40mm  
F-37 3 elements surface box for vertical installation  
86x230x40mm  
Boîte saillie pour installation verticale F-37 3 éléments  
86x230x40mm

37

403

51 Níquel satinado  
Satin nickel-plated  
Niquel satiné

ref. 2











Caja de superficie instalación horizontal F-37 3 elementos  
86x230x40mm  
F-37 3 elements surface box for horizontal installation  
86x230x40mm  
Boîte saillie pour installation horizontale F-37 3 éléments  
86x230x40mm

37

406

51 Níquel satinado  
Satin nickel-plated  
Niquel satiné

1 Unidad Unit Unité

		Serie Set Série	Código Code Cod	Acabado Finish Finition	Embalaje Packaging Emballage	
 	<p>Caja de empalmes F-37 1 elemento 86x86x40mm F-37 1 element wall connection box 86x86x40mm Boîte de dérivation F37 1 élément 86x86x40mm</p>	37	400	51 Níquel satinado Satin nickel-plated Niquel satiné	ref. 2 	
 	<p>Caja de empalmes F-37 2 elementos 86x160x40mm F-37 2 elements wall connection box 86x160x40mm Boîte de dérivation F37 2 éléments 86x160x40mm</p>	37	399	51 Níquel satinado Satin nickel-plated Niquel satiné	ref. 2 	1 Unidad Unit Unité
 	<p>Caja de empalmes rectangular 175x125x50 mm Rectangular wall connection box 175x125x50 mm Boîte de dérivation rectangulaire 175x125x50 mm</p>	30	402	51 Níquel satinado Satin nickel-plated Niquel satiné	ref. 2 	1 Unidad Unit Unité

NEW



Caja de superficie 2 elementos Venezia & Garby Colonial metal envejecido para instalación horizontal  
Venezia & Garby Colonial 2 elements aged metal surface box for horizontal installation  
Boîte saillie pour installation horizontale Venezia & Garby Colonial métal vieilli 2 éléments

Caja de superficie 2 elementos Venezia & Garby Colonial metal envejecido para instalación vertical  
Venezia & Garby Colonial 2 elements aged metal surface box for vertical installation  
Boîte saillie pour installation verticale Venezia & Garby Colonial métal vieilli 2 éléments

Serie  
Set Série

Código  
Code Cod

Acabado  
Finish Finition

Embalaje  
Packaging Emballage

35

408

22 Metal envejecido  
Aged metal  
Métal vieilli

ref. 2 

35

409

22 Metal envejecido  
Aged metal  
Métal vieilli

1 Unidad Unit Unité

NEW



Caja de superficie 2 elementos Venezia & Garby Colonial níquel satinado para instalación horizontal  
Venezia & Garby Colonial 2 elements nickel-plated surface box for horizontal installation  
Boîte saillie pour installation horizontale Venezia & Garby Colonial níquel satiné 2 éléments

Caja de superficie 2 elementos Venezia & Garby Colonial níquel satinado para instalación vertical  
Venezia & Garby Colonial 2 elements nickel-plated surface box for vertical installation  
Boîte saillie pour installation verticale Venezia & Garby Colonial níquel satiné 2 éléments

35

408

51 Níquel satinado  
Satin nickel-plated  
Níquel satiné

ref. 2 

35

409

51 Níquel satinado  
Satin nickel-plated  
Níquel satiné

1 Unidad Unit Unité



**Cajas metálicas de dos elementos para la instalación de mecanismos y accesorios Venezia Rocking & Rotary y Garby Colonial.**

**Foto: Caja metal envejecido + interruptores Garby Colonial de porcelana.**

Two elements metallic boxes to install Rocking and Rotary Venezia and Garby Colonial mechanisms and accessories.

Photo: Aged metal Box + Porcelain Garby Colonial switches.

*Boîtes métalliques de deux éléments pour l'installation de mécanismes et accessoires Venezia Rocking et Rotary, et Garby Colonial.*

*Photo: Boîte métal vieilli + interrupteurs Garby Colonial en porcelaine.*





[www.tesli.com](http://www.tesli.com)

[www.tesli.com](http://www.tesli.com)

[www.tesli.com](http://www.tesli.com)



Interiorismo: Carmen Barasona  
Interior Design: Carmen Barasona  
Architecture d'intérieur: Carmen Barasona













www.eslii.com

www.eslii.com

www.eslii.com

Interiorismo: Salvador Fresneda – Fotografía: Jordi Canosa  
Interior Design: Salvador Fresneda – Photography: Jordi Canosa  
Architecture d'intérieur: Salvador Fresneda – Photographie: Jordi Canosa



	Serie Set Série	Código Code Cod	Acabado Finish Finition	Embalaje Packaging Emballage	
	30	680	15 Roble Oak Chêne	ref. 2 	
	30	681	15 Roble Oak Chêne		
	30	330	02 Negro Black Noir	ref. 2 	1 Unidad Unit Unité
	14	310	50 Dorado Golden Doré 51 Niquelado Nickel-plated Niquelé	ref. 2 	
					25 Unidades Units Unités
	14	010	02 Negro Black Noir 50 Dorado Golden Doré 51 Niquelado Nickel-plated Niquelé	ref. 2 	1 Unidad Unit Unité



		Serie Set Série	Código Code Cod	Acabado Finish Finition	Embalaje Packaging Emballage	
	Pulsador timbre porcelana 10A - 250V~24V DC con bastidor metálico Pushbutton switch 10A - 250V~ 24V DC with metallic chassis Bouton poussoir en porcelaine 10A - 250V~24V DC avec châssis métallique	14	011	17 Porcelana Porcelain Porcelaine	ref. 2 	Para empotrar en caja universal For fitting in universal box A encastrer dans un boîtier standard
	Pulsador porcelana decorado en dorado 10A - 250V~24V DC con bastidor metálico Porcelain pushbutton with golden decor 10A - 250V~ 24V DC with metallic chassis Bouton poussoir en porcelaine avec décorations dorées 10A - 250V~24V DC avec châssis métallique	14	011	30 Dorado/Blanco Gold/White Doré/Blanc	ref. 2 	Para empotrar en caja universal For fitting in universal box A encastrer dans un boîtier standard
	Pulsador timbre madera 10A - 24V DC con bastidor metálico 110x85 mm 28 profundidad Wood pushbutton 10A - 24V DC with metallic chassis 110x85 mm 28 depth Bouton poussoir en bois 10A - 24V DC avec châssis métallique 110x85 mm; 28 profondeur	14	013	00 Haya Crudo Natural Beech Hêtre brut  20 Haya Color Nogal Beech Walnut Colored Hêtre Couleur noyer	ref. 2 	Para empotrar en caja universal For fitting in universal box A encastrer dans un boîtier standard
	Pulsador timbre madera 10A - 24V DC ø 98 mm con bastidor metálico Wood pushbutton 10A - 24V DC ø 98 mm with metallic chassis Bouton poussoir en bois 10A - 24V DC ø 98 mm avec châssis métallique	14	014	00 Haya Crudo Natural Beech Hêtre brut  20 Haya Color Nogal Beech Walnut Colored Hêtre Couleur noyer	ref. 2 	Posibilidad de personalización de los marcos en acabado crudo Possible custom-made finishes with natural wood frames Possibilité de personnaliser les plaques en bois naturel  Ver esquemas de instalación en la página 103. See installation instructions at page 103. Voir les schémas de montage à la page 103.  Para empotrar en caja universal For fitting in universal box A encastrer dans un boîtier standard

1 Unidad Unit Unité

1 Unidad Unit Unité

1 Unidad Unit Unité

1 Unidad Unit Unité

Código  
Code Code

Acabado  
Finish Finition

Código  
Code Code

Acabado  
Finish Finition

Código  
Code Code

Acabado  
Finish Finition



35 · 928 · 212

**Madera envejecida**  
Old wood  
Bois vieilli

For Garby, Garby  
Colonial and Venezia  
Collections



35 · 928 · 002

**Madera crudo**  
Natural wood  
Bois brut

For Garby, Garby  
Colonial and Venezia  
Collection



35 · 928 · 192

**Madera color miel**  
Honey colour wood  
Bois couleur miel

For Garby, Garby  
Colonial and Venezia  
Collections



35 · 928 · 302

**Latón dorado**  
Gold-plated brass  
Laiton doré

For Garby, Garby  
Colonial and Venezia  
Collections



35 · 928 · 512

**Latón niquelado**  
Nickel-plated brass  
Laiton niquelé

For Garby, Garby  
Colonial and Venezia  
Collections



35 · 928 · 592

**Latón patiné americano**  
Antique bronze brass  
Laiton bronze ancien

For Garby, Garby  
Colonial and Venezia  
Collections



37 · 928 · 252

**Acero inox**  
Stainless steel  
Acier inox

For F37 and Venezia  
Collections



37 · 928 · 302

**Latón dorado**  
Golden brass  
Laiton doré

For F37 and Venezia  
Collections



37 · 928 · 592

**Latón patiné americano**  
Antique bronze brass  
Laiton bronze ancien

For F37 and Venezia  
Collections



35 · 928 · 172

**Porcelana**  
Porcelain  
Porcelaine

For Garby, Garby  
Colonial and Venezia  
Collections



35 · 928 · 272

**Porcelana negra**  
Black porcelain  
Porcelaine noire

For Garby, Garby  
Colonial and Venezia  
Collections

**Posibilidad de personalización de los marcos en acabado crudo**  
Possible custom-made finishes with natural wood frames  
Possibilité de personnaliser les plaques en bois naturel



35 · 930 · 172

**Porcelana retro**  
Porcelain retro key  
Porcelaine rétro

For Garby, Garby  
Colonial and Venezia  
Collections



35 · 930 · 272









**Porcelana negra retro**  
Black porcelain retro key  
Porcelaine noire rétro

For Garby, Garby  
Colonial and Venezia  
Collections

	Código Code Code	Acabado Finish Finition		Código Code Code	Acabado Finish Finition		Código Code Code	Acabado Finish Finition
	35 · 929 · 302	<b>Latón dorado</b> Gold-plated brass Laiton doré  For Venezia Rotary Collection		35 · 929 · 512	<b>Latón niquelado</b> Nickel-plated brass Laiton niquelé  For Venezia Rotary Collection		35 · 929 · 592	<b>Latón patiné americano</b> Antique bronze brass Laiton bronze ancien  For Venezia Rotary Collection
	67 · 929 · 302	<b>Latón dorado</b> Gold-plated brass Laiton doré  For F37 and Venezia Rocking Collections		67 · 929 · 262	<b>Latón cromado</b> Chrome-plated brass Laiton chromé  For F37 and Venezia Rocking Collections		67 · 929 · 592	<b>Latón patiné americano</b> Antique bronze brass Laiton bronze ancien  For F37 and Venezia Rocking Collections
	65 · 929 · 302	<b>Latón dorado</b> Gold-plated brass Laiton doré  For Venezia Rocking Collection		65 · 929 · 262	<b>Latón cromado</b> Chrome-plated brass Laiton chromé  For Venezia Rocking Collection		65 · 929 · 592	<b>Latón patiné americano</b> Antique bronze brass Laiton bronze ancien  For Venezia Rocking Collection





	Serie Set Série	Código Code Cod	Acabado Finish Finition	Embalaje Packaging Emballage	
 <p>Central de sonido 1 canal Entrada de señal estéreo baja impedancia de 1V a 20V Salida estéreo autocontrolada Telecontrol para desconectar fuentes externas Conmutador para conectar y desconectar altavoces Alimentación 220V/40VA Fusibles de rearme automático Fuente de alimentación para 12 mandos digitales Amplificador para 15 mandos analógicos</p>	95	946	05	ref. 2 	<p>Sound central for 1 channel Low impedance stereo input from 1V to 20V Self-controlled stereo output Switch to connect/disconnect speakers Power 220V/20VA Fuses of automatic rearm Power supply for 12 digital controls Amplifier for 15 analogue controls</p> <p>Centrale de son 1 canal Entrée de signal stéréo basse impédance 1V à 20V Sortie stéréo autocontrôlée Va-et-vient pour connecter/déconnecter haut-parleurs Alimentation 220V/40VA Source d'alimentation pour 12 contrôles numériques Amplificateur pour 15 contrôles analogiques</p>
 <p>Central de sonido 1 canal con sintonizador FM Mismas características que ref. 95.946.. Sintonizador FM incorporado Conmutador fuente musical / sintonizador FM</p> <p>Sound central for 1 channel with FM tuner Same features than ref. 95.946.. FM tuner included Switch between music source/FM tuner</p> <p>Centrale de son pour 1 canal avec tuner FM Mêmes caractéristiques que réf. 95.946.. Tuner FM inclus. Va-et-vient pour sélectionner fond musical ou tuner FM</p>	95	947	05	ref. 2 	<p>1 Unidad Unit Unité</p>
 <p>Embellecedor frontal para central de sonido Frontal frame for sound central Cadre frontal pour centrale de son</p>	95	802	05	ref. 2 	<p>1 Unidad Unit Unité</p>
 <p>Caja para instalación en superficie Box for surface installation Boite pour installation en saillie</p>	95	910	05	ref. 2 	<p>1 Unidad Unit Unité</p>



# INFORMACIÓN TÉCNICA TECHNICAL INFORMATION *INFORMATION TECHNIQUE*

[www.tesli.com](http://www.tesli.com)

[www.tesli.com](http://www.tesli.com)

[www.tesli.com](http://www.tesli.com)

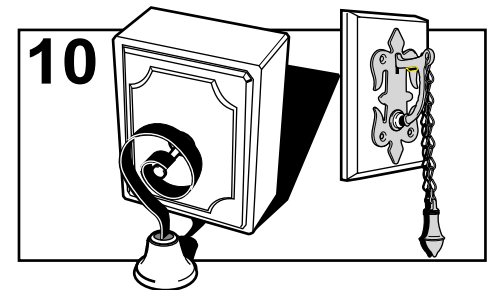
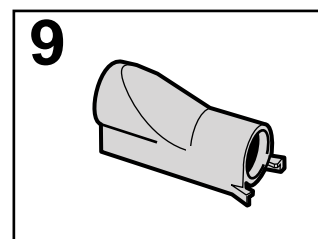
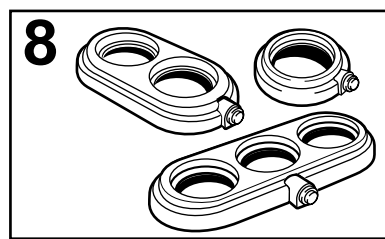
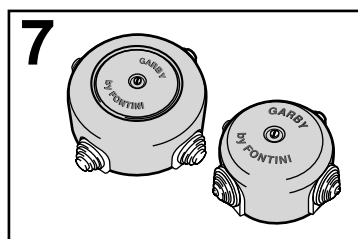
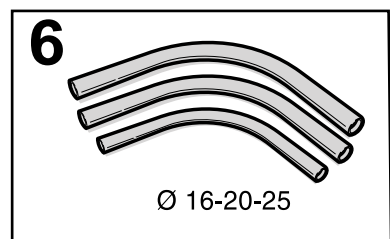
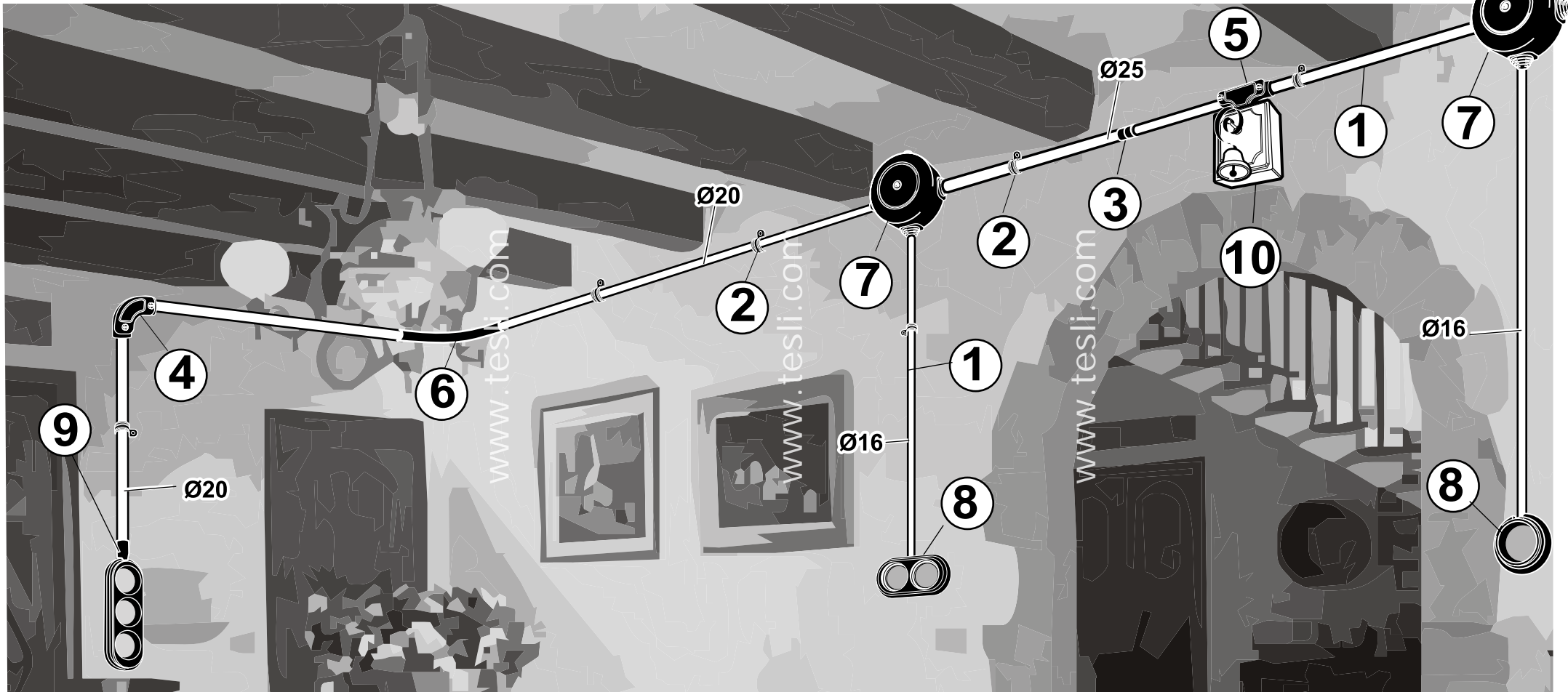
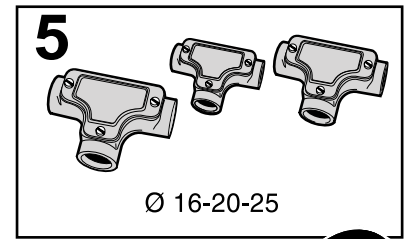
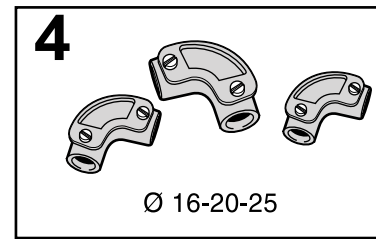
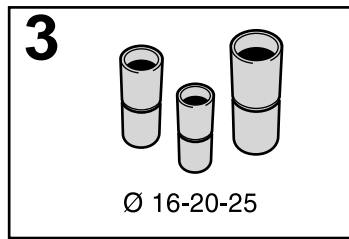
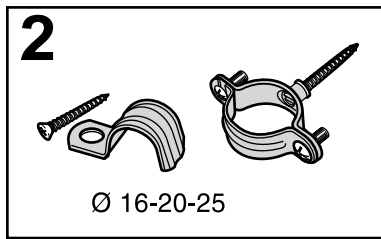
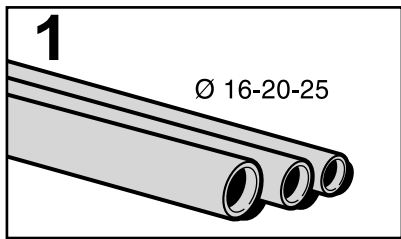



CARACTERISTICAS GENERALES

7

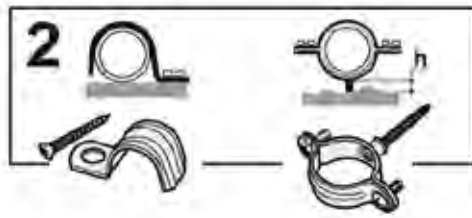
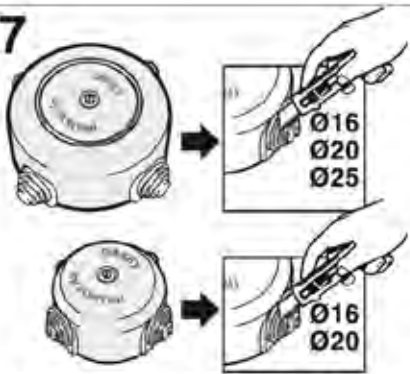

4-5

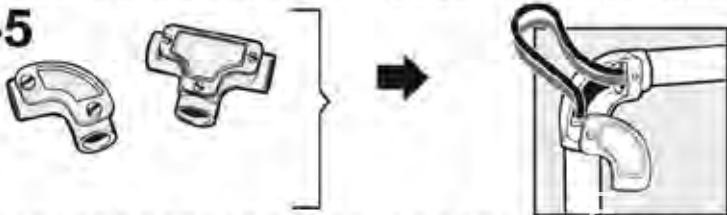

8

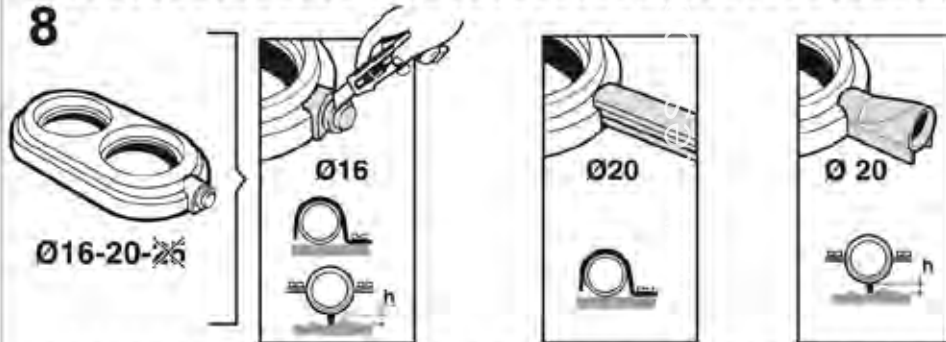

1

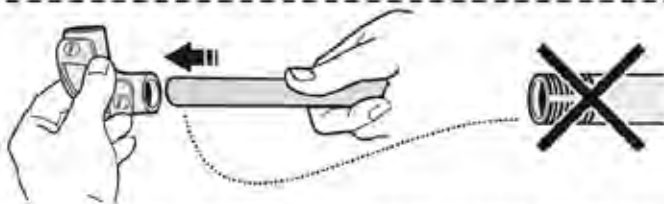

10

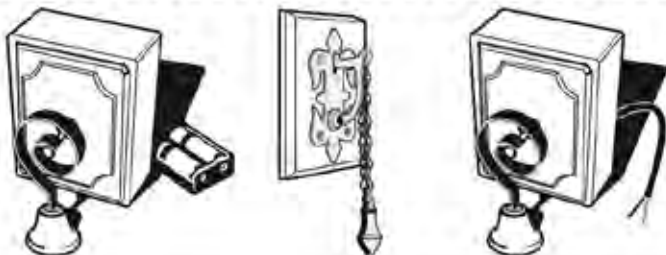

## Instrucciones mecanismos / Instructions pour mécanismes Instructions for Mechanisms



Garby



Dimbler

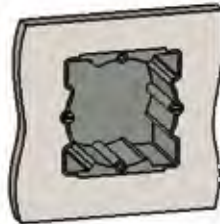

caja univ. con tornillos  
boîte std avec vis  
universal box with screws



caja univ. sin tornillos  
boîte std sans vis  
universal box without screws



Pared  
Mur  
Wall

a) peana Garby  
socle Garby  
Garby base



b) marco Venezia/G.Col.  
cadre Venezia/G.Col.  
Venezia/G.Col frame



c) peana Garby  
socle Garby  
Garby base



d) peana Garby  
socle Garby  
Garby base



e) marco V./G.Col.  
cadre V./G.Col.  
V./G.Col frame



f) (nada)  
(rien)  
(nothing)

necesario  
nécessaire  
necessary



30-951-98

necesario  
nécessaire  
necessary



20-901-97

necesario  
nécessaire  
necessary



30-950-98

- A** Con peana Garby en caja universal con tornillos  
*Avec socle Garby sur boîte standard avec vis*  
 With Garby base on universal box with screws

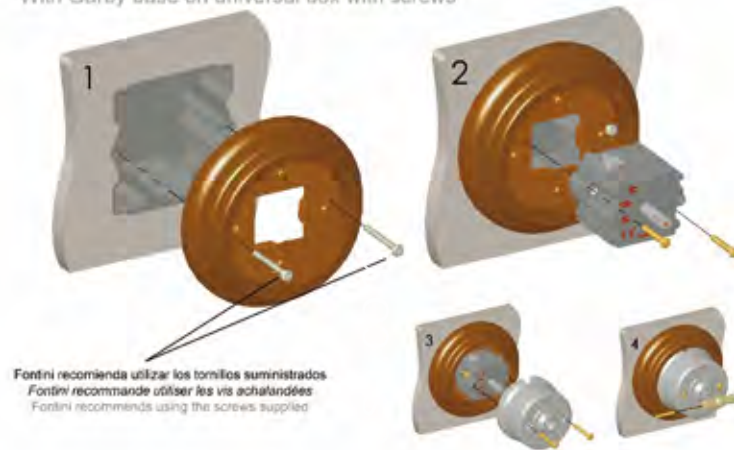

- B** Con marco Venezia\* o Garby Colonial en caja universal con tornillos  
*Avec cadre Venezia\* ou Garby Colonial sur boîte standard avec vis*  
 With Venezia\* or Garby Colonial frame on universal box with screws

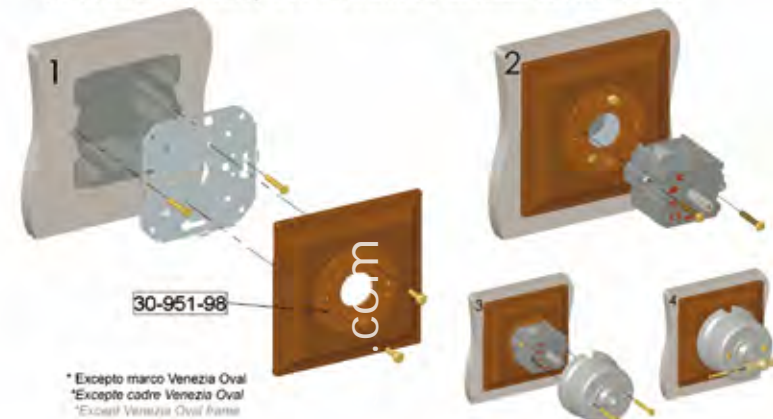

- C** Con peana Garby en caja universal Sin tornillos  
*Avec socle Garby sur boîte standard sans vis*  
 With Garby base on universal box without screws



- D** Con peana Garby en pared  
*Avec socle Garby sur mur*  
 With Garby base on wall





**E** Con marco Venezia\* o Garby Colonial en pared  
 Avec cadre Venezia\* ou Garby Colonial sur mur  
 With Venezia\* or Garby Colonial frame on wall

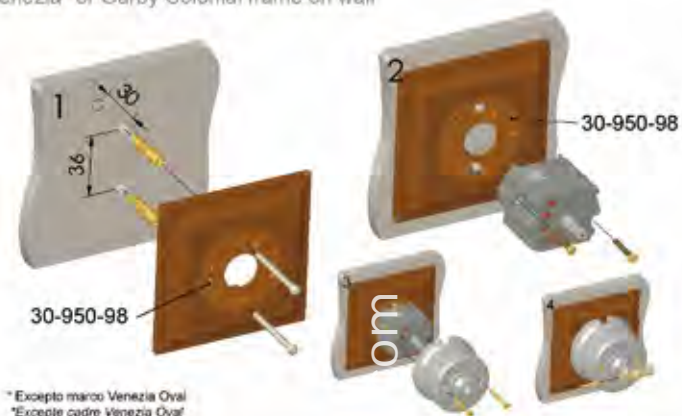

\*Excepto marco Venezia Oval  
 \*Excepte cadre Venezia Oval  
 \*Except Venezia Oval frame

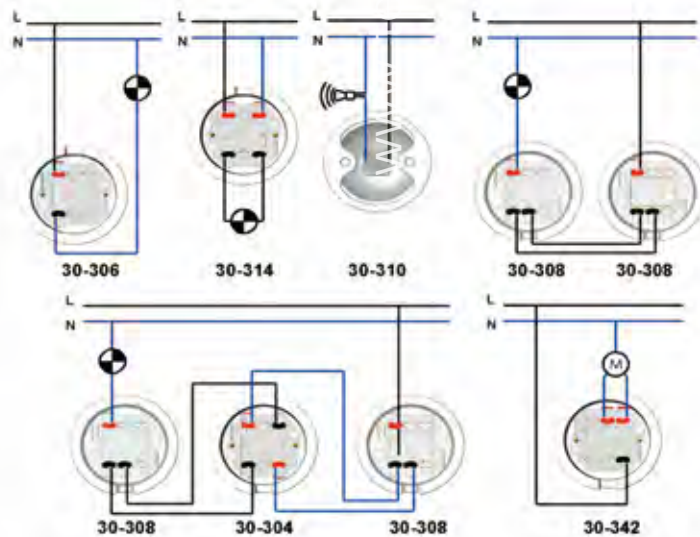

Esquemas de conexión Garby  
 Schèmes de connexion Garby  
 Garby connection schemes

**F** Instalacion en pared / Installation sur mur  
 Installation on wall

30-306, 30-308, 30-304, 30-314,  
 30-342, 30-343, 30-700/2 o 30-927



30-209, 30-204,  
 30-208, 30-310 o 30-710/1

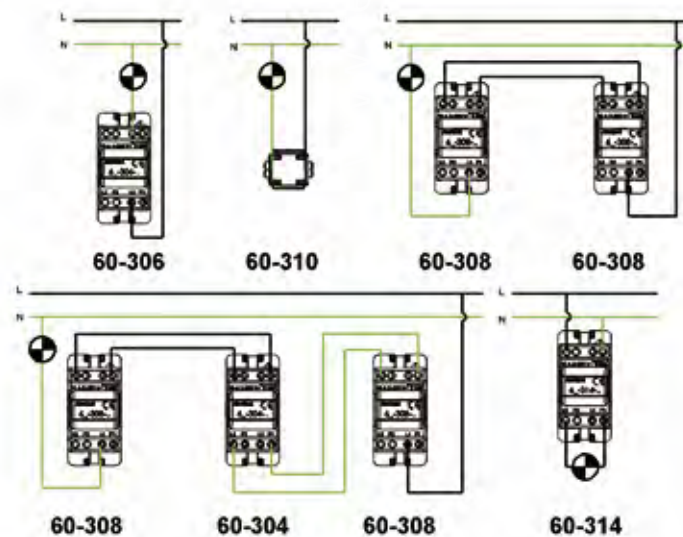
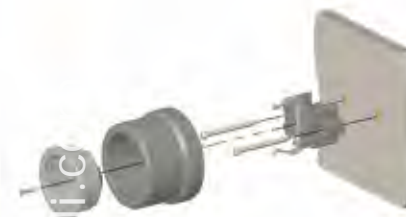

Esquemas de conexión Dimbler  
 Schèmes de connexion Dimbler  
 Dimbler connection schemes



**A** Montaje de mecanismo Venezia  
Assembling of Venezia mechanism  
Montage du mécanisme Venezia

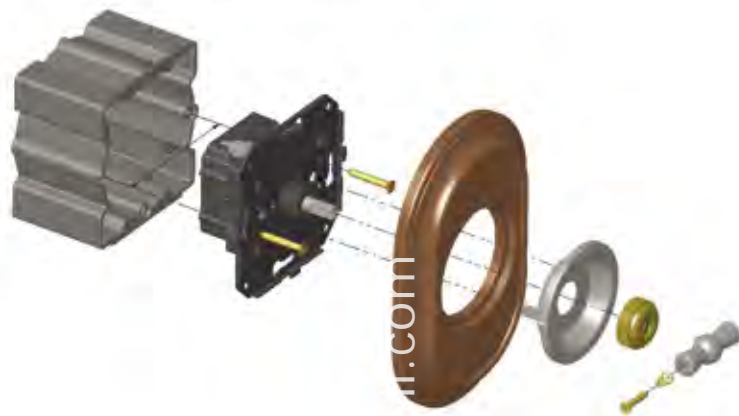

**C** Montaje de mecanismo Garby Colonial  
Assembling of Garby Colonial mechanism  
Montage du mécanisme Garby Colonial

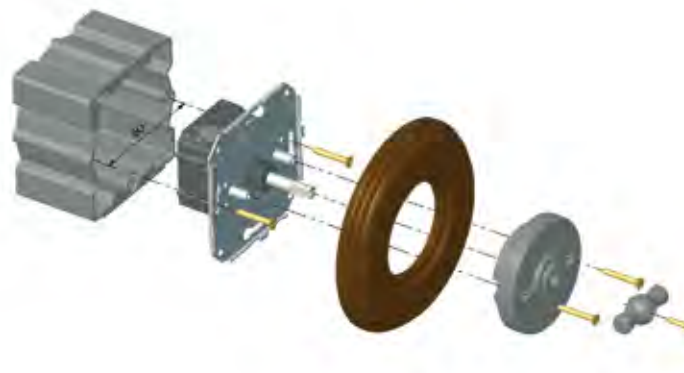

**B** Montaje de mecanismo F-37  
Assembling of F-37 mechanism  
Montage du mécanisme F-37

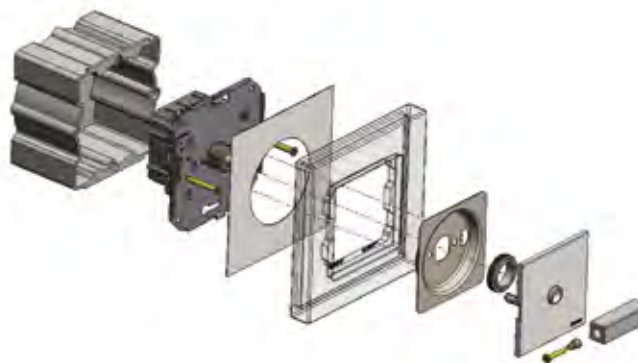

# VENEZIA / GARBY COLONIAL / F-37

## Esquemas de conexión Connection schemes

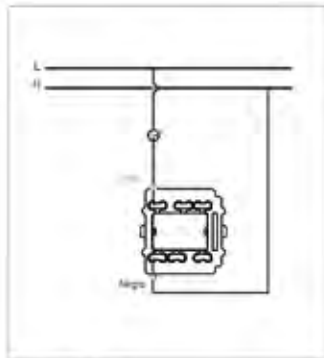

Interruptor Switch

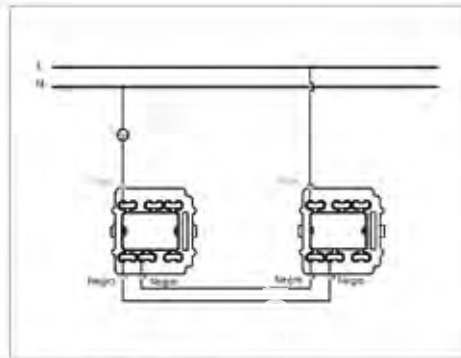

Conmutador Two-way Switch

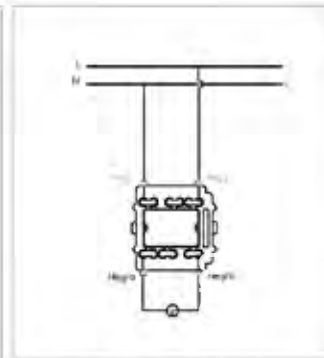

Interruptor bipolar Two-pole switch

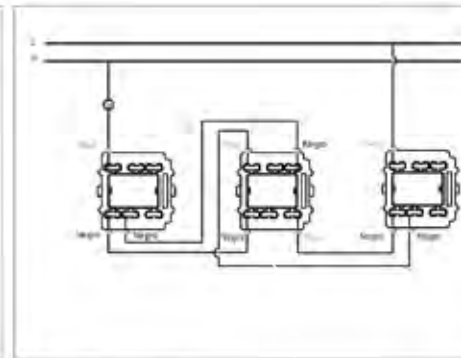

Cruzamiento Crossing Switch

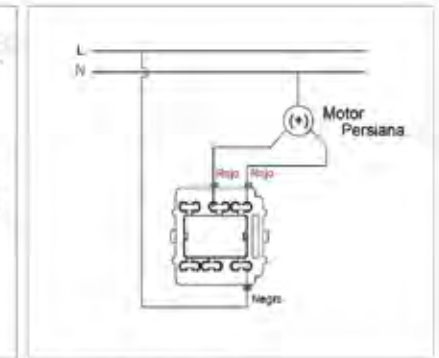

Mecanismos para persianas  
Electric blinds mechanism

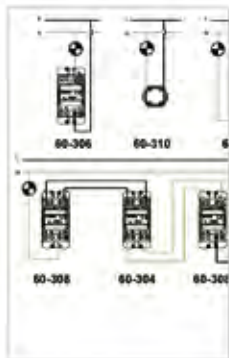

Pulsador Pushbutton

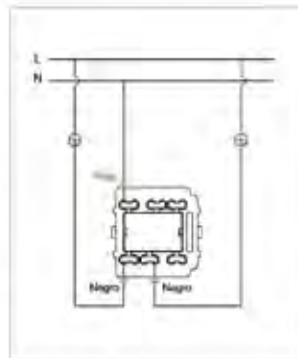

Doble interruptor Double switch

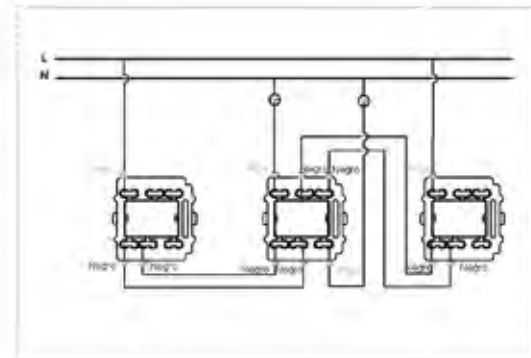

Doble conmutador Double two-way switch

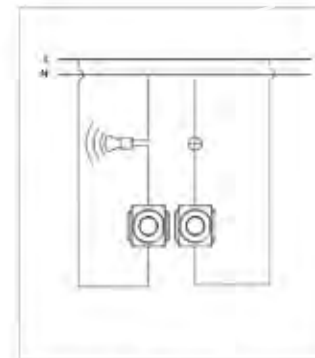

Doble pulsador Double pushbutton

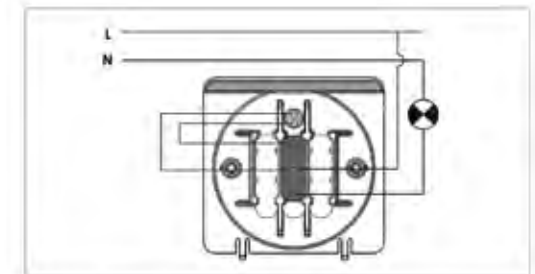

Tarjetero Cards mechanism

# ROCKING SWITCHES

Montaje de mecanismo F-37  
Assembling of F-37 mechanism  
Montage du mécanisme F-37

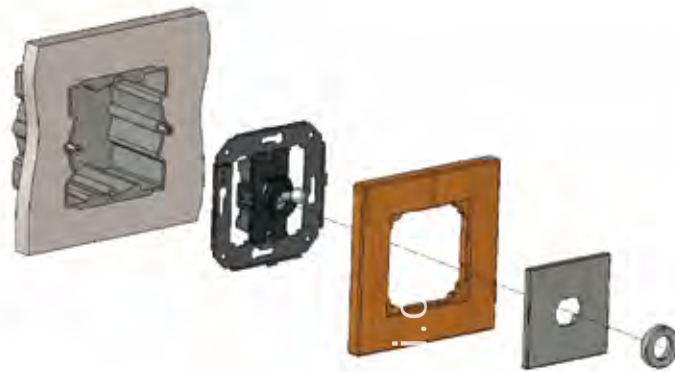

Montaje de mecanismo Venezia  
Assembling of Venezia mechanism  
Montage du mécanisme Venezia

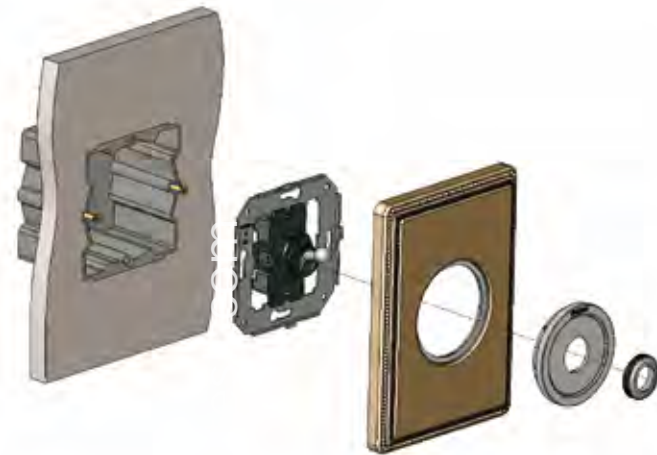

Esquemas de conexión Venezia/ F-37  
Schèmes de connexion Venezia/ F-37  
Venezia/ F-37 connection schemes

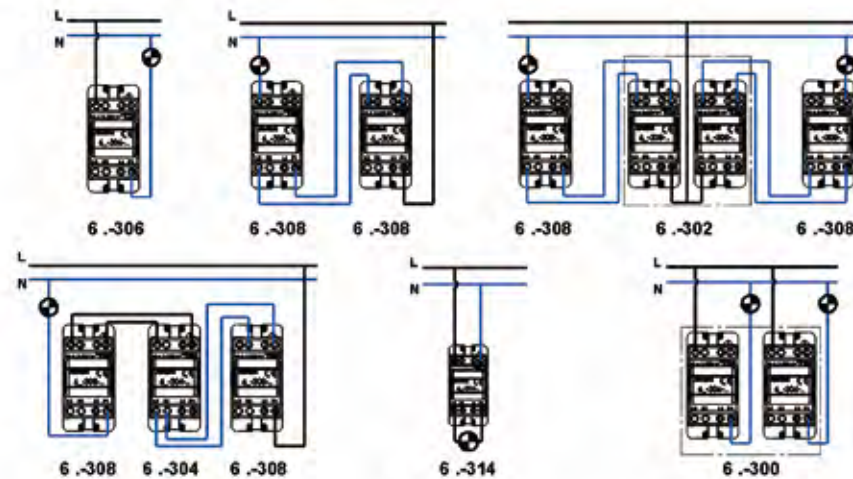

Ref. 31-332, Ref. 35-332 y Ref. 37-332

## Esquemas de conexión regulador-conmutador

### Descripción

Consumo lo que usted necesita, regulando la intensidad de la lámpara a su gusto. Sustituye a los conmutadores convencionales, es adaptable a las cajas universales de empotrar, sin necesidad de modificar la instalación actual.

Es válido para:

- Lámparas de incandescencia y halógenas de 40W a 500W.
- Transformadores toroidales desde 50W a 500W.
- Transformadores electromecánicos de 90W a 500W.
- Funciona como simple interruptor, como conmutador y en combinación de conmutador y cruzamiento.

### Características

- Clase II
- IP 20
- IRC > 450 V
- Protegido mediante fusible rápido F 2.5 A

## Connection schemes of dimmer - two-way switch

### Description

Only consumes what you need, regulating the lamp intensity as you like. It substitutes the conventional switches and adaptable to fitting standard boxes. The current installation does not have to be modified.

Suitable for:

- Incandescence and halogen bulbs from 40W to 500W.
- Toroidal transformers from 50W to 500W
- Electromechanical transformers from 90W to 500W
- Works as a simple switch, as a two way switch or combined with a two way switch and a crossing switch

### Characteristics

- II Class
- IP 20
- IRC > 450 V
- Protected with a fast fuse F 2.5 A

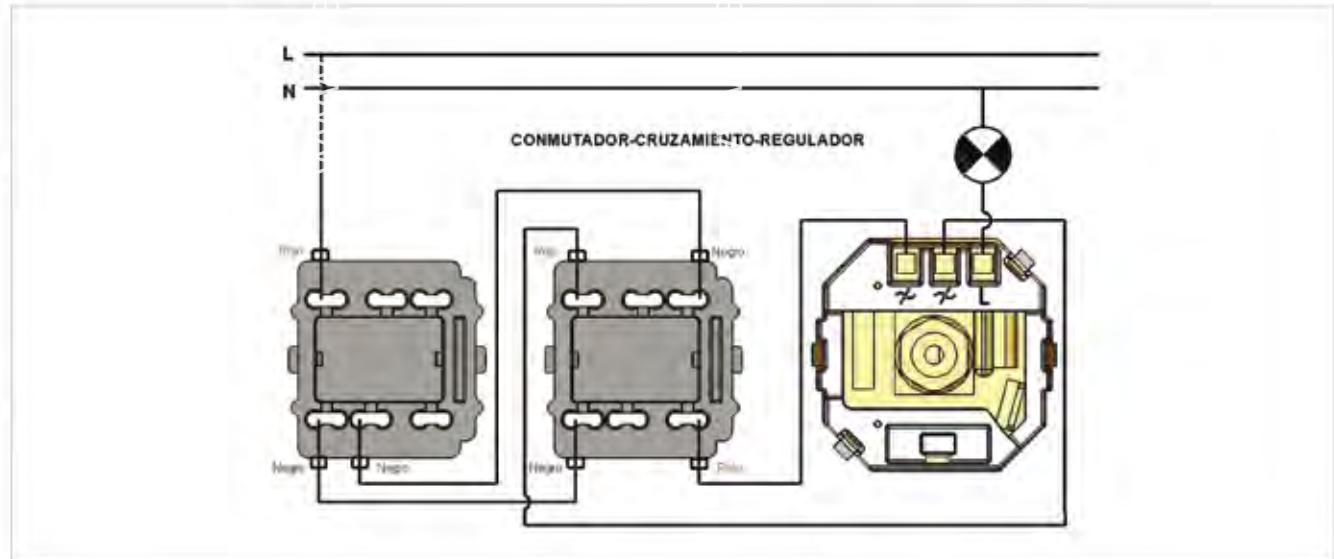
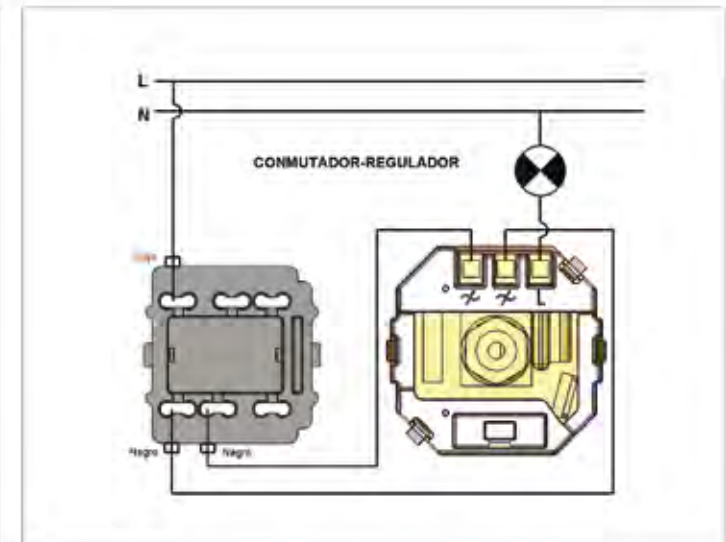
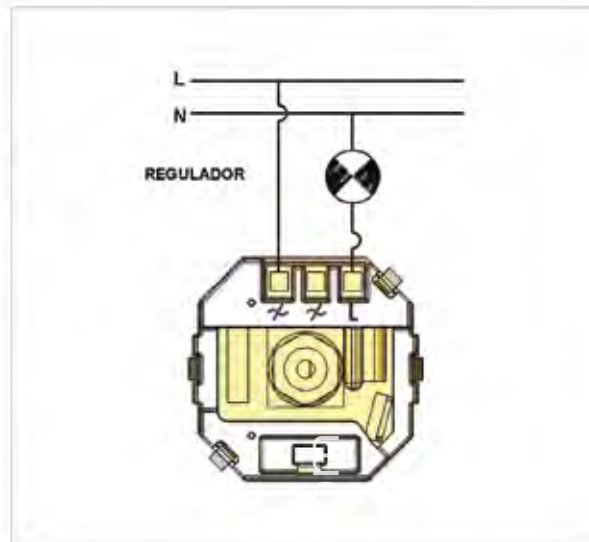

NOTA: En un mismo circuito sólo puede conectarse un regulador-conmutador en combinación con un conmutador simple, pero nunca con otro regulador-conmutador.  
IMPORTANT: At the same circuit only one dimmer-two-way switch can be used, combined with a simple two-way switch. Never use two dimmers together!



# RTV - SAT

Toma señal TV, Radio y FI ecualizada  
TV, Radio and FI equalized signal socket

F-37 · Venezia · Garby Colonial  
Refs. 35-711, 35-712, 35-713, 35-714  
30-712, 30-714, 30-713, 30-709  
37-711, 37-712, 37-713, 37-714

Referencia Reference	Tipo Type	Pérd. inserción (dB) Insertion loss (dB)		SALIDA OUT	Pérd. inserción (dB) Insertion loss (dB)	
		MATV	SAT-FI		MATV	SAT-FI
		5-862 MHz	950-2150 MHz		5-862 MHz	950-2150 MHz
30-712 35-712 37-712	Única Single	-	-	R/TV SAT	0,6 -	- 1,5
30-714 35-714 37-714	Intermedia B Intermediate B	1,02	2	R/TV SAT	13 13	13,5 14
30-713 35-713 37-713	Intermedia A Intermediate A	3,5	5	R/TV SAT	8,5 7,5	9 10
30-709 35-711 37-711	Final T	-	-	R/TV SAT	4 4	5 5

Máximo número de tomas: 8 (dependiendo de la potencia de la señal de entrada).  
Maximum number of sockets: 8 (depending on the entering signal power).

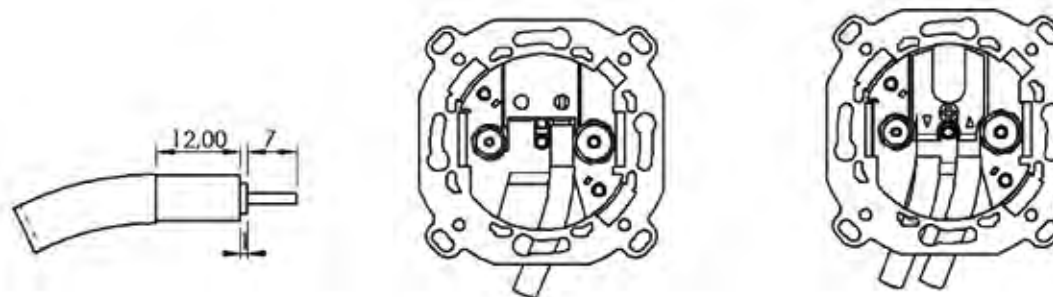
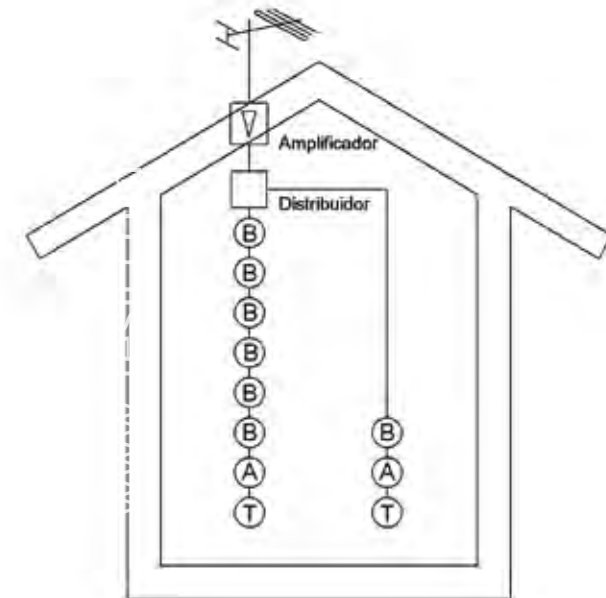
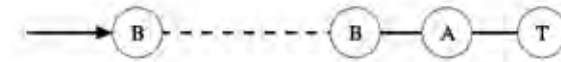

Doble toma teléfono 4-6 vías. Esquema de conexión.  
 Double telephone socket 4-6 ways. Connection schemes.

1 línea (las dos tomas la misma línea) 1 line (two sockets in the same line)

2 líneas independientes 2 independent lines

Esquema de conexión interna  
 Internal Connection Schemes

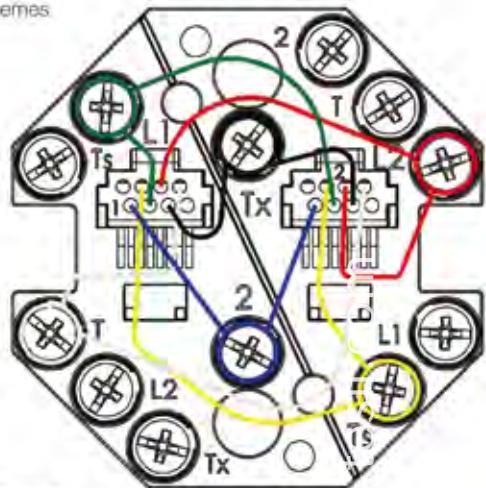

Esquema de conexión externa  
 External Connection Schemes

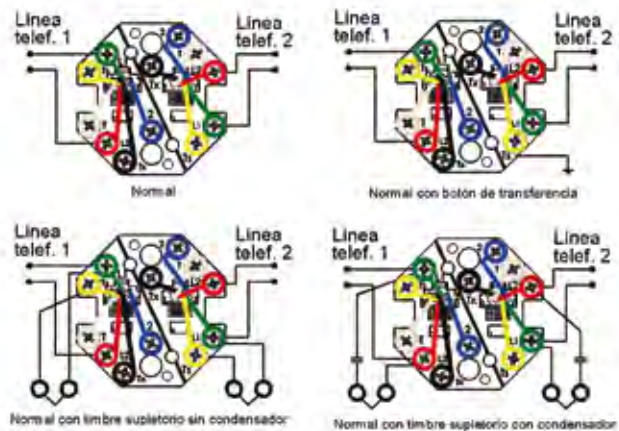

Esquema de conexión interna  
 Internal Connection Schemes

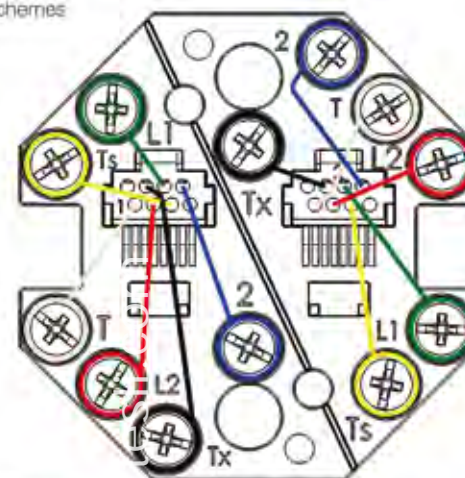

Esquema de conexión externa  
 External Connection Schemes

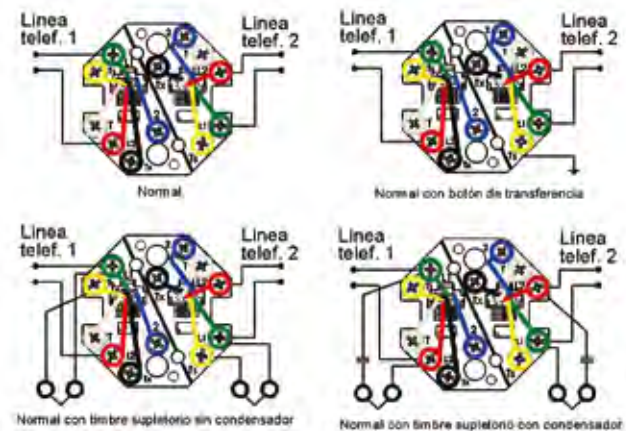

# TELÉFONO / TELEPHONE / TÉLÉPHONE

Toma teléfono 4 y 6 vías · Esquema de conexión  
4 and 6 ways telephone sockets · Connection schemes.

Correspondencia entre el color del conductor y los terminales  
Correspondence between wire colour and terminals:

Color del conductor Wire colour	Terminal Terminal
BLANCO WHITE BLANC	T
NEGRO BLACK NOIR	T <sub>x</sub>
ROJO RED ROUGE	L <sub>2</sub>
VERDE GREEN VERT	L <sub>1</sub>
AMARILLO YELLOW JAUNE	T <sub>S</sub>
AZUL BLUE BLEU	2

Refs.

3X-700 · 4 Vías

3X-700 · 4 Ways

3X-701 · 6 Vías

3X-701 · 6 Ways

4 Vías · 4 Ways

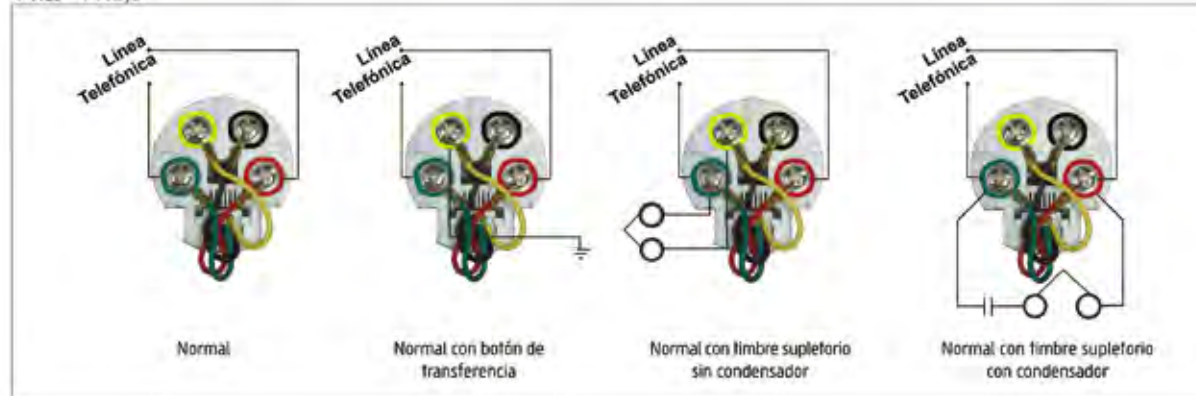

6 Vías · 6 Ways

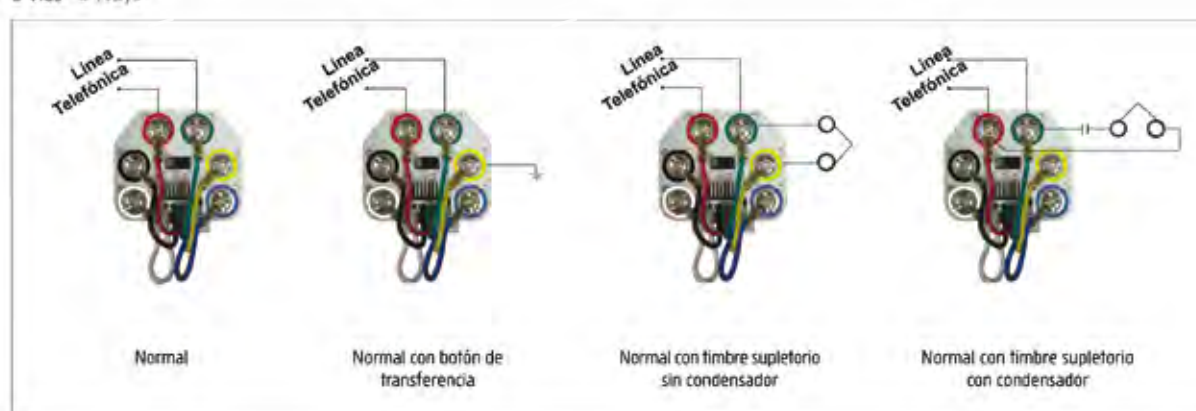



## Sonido · Ficha técnica y esquemas de conexión

Sound · Technical file and connection schemes

### Sistema de sonido colecciones Garby Colonial, F-37 y Venezia

Garby Colonial, F-37 and Venezia collections sound system

#### DESCRIPCIÓN

##### Sintonizador de radio (Ref. 31-925, 35-925)

- Compatible únicamente con centrales de sonido. Ref. 95947050
- Búsquedas de emisoras SCAN (sintoniza la emisora desde el mando mediante pulsación).
- Regulador de volumen mediante giro del mando.
- Instalación estéreo o monofónica.
- Impedancia mínima de carga: 8 Ω.
- Máximo número de altavoces en paralelo por canal:
  - De 1 a 4 altavoces de 32 Ω.
  - De 1 a 2 altavoces de 16 Ω.
  - De 1 de 8 Ω.
- Máximo número de altavoces en serie por canal:
  - 1 altavoz de 32 Ω.
  - De 1 a 2 de 16 Ω.
  - De 1 a 4 de 8 Ω.
- Margen de regulación: 32 dB.

##### Potenciómetro (Ref. 31-924, 35-924 y 37-924)

- Compatible con Ref. 95946050 o con cualquier amplificador.
- Regulador de volumen.
- Instalación estéreo o monofónica.
- Impedancia mínima de carga: 8 Ω.
- De 1 a 4 altavoces de 32 Ω, 1 ó 2 de 16 Ω ó 1 de 8 Ω por canal.
- Margen de regulación: 32 dB.

##### Altavoz para caja universal (Ref. 31-926, 35-926 y 37-926)

- Potencia 2 W.
- Impedancia 16 Ω.
- Sensibilidad: 82 dB.
- Respuesta: 150-16.000 Hz.
- Ángulo de cobertura: 155°.

#### DESCRIPTION

##### Radio Tuner (Refs. 31-925, 35-925)

- Only compatible with sound centrals. Ref. 95947050
- Seek of radio stations with SCAN system (tunes automatically with one touch).
- Regulates the volume by turning the control right or left.
- Stereo or Mono installations.
- Minimal load impedance: 8 Ω.
- Maximum number of loudspeakers in parallel by channel:
  - From 1 to 4 of 32 Ω.
  - From 1 to 2 of 16 Ω.
  - One loudspeakers of 8 Ω.
- Maximum number of loudspeakers in serial by channel:
  - One Loudspeaker of 32 Ω.
  - From 1 to 2 of 16 Ω.
  - From 1 to 4 of 8 Ω.
- Regulation range: 32 dB.

##### Potentiometer (Refs. 31-924, 35-924, 37-924)

- Compatible with Ref. 95946050 or any amplifier.
- Volume regulator.
- Stereo or Mono installation.
- Minimal load impedance: 8 Ω.
- From 1 to 4 loudspeakers of 32 Ω, 1 or 2 of 16 Ω or 1 of 8 Ω by channel.
- Regulation range: 32 dB.

##### Loudspeaker for universal box 65x65x40 (Ref.31-926, 35-926, 37-926)

- Power 2 W.
- Impedance 16 Ω.
- Sensitivity: 82 dB.
- Response: 150-16.000 Hz
- Coverage angle: 155°.

Refs.

31-92X

35-92X

37-92X

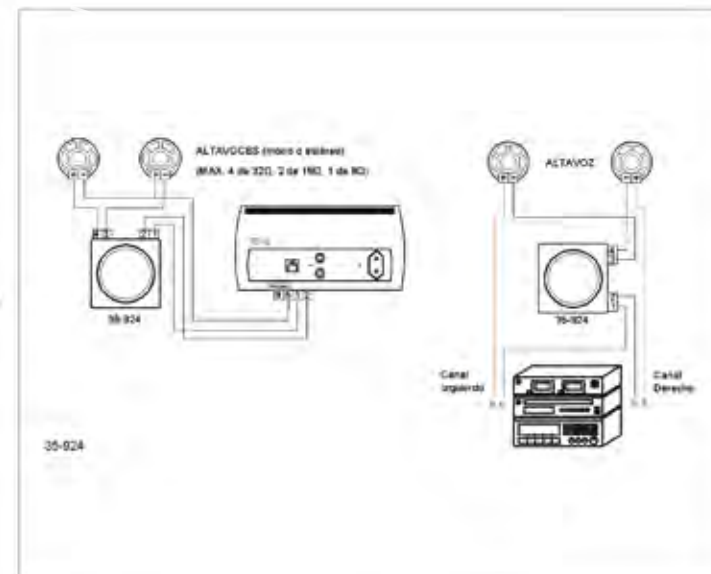
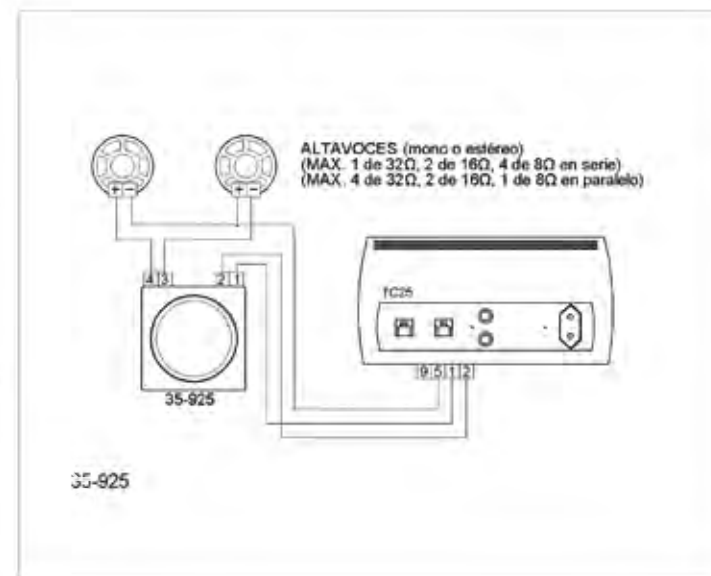





[www.tesli.com](http://www.tesli.com)

[www.tesli.com](http://www.tesli.com)

[www.tesli.com](http://www.tesli.com)

Interiorismo: **Xavier Cruz** - Fotografía: **Jordi Canosa**  
Interior Design: **Xavier Cruz** - Photography: **Jordi Canosa**  
Architecture d'intérieur: **Xavier Cruz** - Photographie: **Jordi Canosa**

Collections · News · Novelties · Events · Trade fairs

***www.Fontini.com***

***TODO EL MUNDO FONTINI EN UN SOLO CLICK***

Una herramienta sencilla que le ayudará a encontrar la solución decorativa que mejor se adapte a sus necesidades.

An easy tool to find the best interior design solution for your needs.

Un outil simple qui vous aidera à trouver la solution décorative qui s'adapte le plus à vos besoins.



***Fontini*** EXPRESS SERVICE 24H

Y en caso de urgencia, Fontini le garantiza la entrega inmediata de su pedido. Contacte con nosotros y consulte condiciones.\*

\* Solo disponible para entregas en península.

***Fontini*** LET'S TALK  
***902 120 103***

©2009 Fontini, S.A.  
Supervisión técnica: Roger Font / Elodie Posso  
Creación y diseño: Dlab Advertising  
Impresión: Impresiones Generales, S.A.  
D. Legal: B-15.336-2009

Catálogo 23

Los colores de los productos fotografiados en este catálogo están sujetos a los cambios de tonalidades propios de los materiales naturales con que están fabricados, así como a las desviaciones cromáticas de la reproducción impresa.

Todas las referencias, códigos y medidas son válidos salvo error tipográfico.

Fontini, S.A. se reserva el derecho a modificar el contenido de este catálogo sin previo aviso.



[www.tesli.com](http://www.tesli.com)

[www.tesli.com](http://www.tesli.com)

[www.tesli.com](http://www.tesli.com)

***Fontini***

[www.fontini.com](http://www.fontini.com)  
Tel. Atención Profesional: 902 120 103

Pol. Ind. Can Bernades-Subirà C/ Anoia, 15 08130  
Santa Perpètua de Mogoda (Barcelona) Spain  
Tel.: (+34) 93.574.33.30 Fax: (+34) 93.574.21.19  
Mail: [info@fontini.com](mailto:info@fontini.com)